



© Marcus Runeson

## USER INSTRUCTIONS

JJ-CCR Rebreather



Version 3.04



Reproduction and changes of this document and its content is prohibited without written approval from JJ-CCR ApS.

All information in this document has been carefully analyzed and is believed to be accurate. However, it is not possible to guarantee its accuracy and all liability is excluded. Cited companies and/ or product names are trademarks belonging to the respective companies.

## General cautionary notes and warnings

- Never use the JJ-CCR Rebreather without receiving specific equipment training (basic course or crossover). It is essential receiving training from a factory approved instructor and from a factory approved training agency.
- These user instructions do not replace training with the equipment and are not directions for diving with closed circuit equipment.
- As with other equipment, it is possible that a Rebreather may fail at any time! It is therefore essential that an autonomous bailout system, independent of the equipment, be taken by the diver on every dive. The bailout system must be configured such that the dive can be terminated without difficulty in the event of a malfunction.
- Your knowledge and practical exercises are the best prerequisites for avoiding accidents.
- Modifications to the equipment result in the CE being voided immediately and it is no longer possible to guarantee a safe dive. This is also the case in the event of a failure to observe the service and maintenance intervals.
- Modifications to the equipment result in the warranty being invalidated. If modified equipment and/or parts are returned for repairs or maintenance then the equipment will be restored to its original format in the factory. Any parts and work required in order to do so will be billed for.
- Replacement parts, repairs and maintenance may only be carried out / shall only be supplied if the owner is able to provide verification that he possesses the requisite equipment-specific training.
- It is highly recommended that the user take the time to read through these user instructions in full.
- If you do not concur with the warnings provided then you should not dive with a JJ-CCR Rebreather.

# 1 Table of contents



1	Table of contents	3
1.1	Revisions and changes in documentation	7
1.2	Manufacturer	7
1.3	Regulation and standards	7
1.4	EC type examination	7
1.5	EU Declaration of Conformity	7
1.6	Risks against which the PPE is intended to protect	7
2	Introduction	8
3	JJ-CCR overview	9
3.1	JJ-CCR Scope of functionality	9
3.2	Technical specifications	10
3.2.1	Vertical head down position	11
3.2.2	Temperature conditions	11
3.2.3	Work rates	11
3.2.4	High-pressure oxygen	11
3.2.5	Expected inspired gas concentrations	12
3.2.6	Visibility	12
3.2.7	Use of high oxygen content gases	12
3.2.8	Potential long term health effects	12
4	Assembly of the JJ-CCR	13
4.1	Base unit	13
4.2	Handle	14
4.3	Stand	14
4.3.1	Attaching the stand to the base unit	15
4.4	1 <sup>st</sup> stages and hoses	16
4.5	Wing	17
4.6	Back-mounted counter lungs (BMCL) and dump valve	17
4.7	Backplate and harness	18
4.7.1	Adjust the harness	19
4.8	Connecting the supplemental valves	20
4.9	Connecting the ADV	21
4.10	Connecting the wing inflator	21
4.11	Soda lime canister (axial)	22
4.12	Soda lime canister (radial)	23
4.13	Lid assembly	24
4.14	Breathing hose with DSV (Dive Surface Valve)	26
5	Main components	27
5.1	Lid	27
5.1.1	Battery compartment	27
5.1.2	Oxygen sensors	28
5.1.3	Solenoid	29
5.1.4	Breathing hoses	29
5.2	Controller	30
5.3	HUD (Head Up Display)	30



5.3.1	Overview	31
5.3.2	PO2 Display	32
5.3.3	Basic Commands	33
5.3.4	Turning On	33
5.3.5	Entering Commands	33
5.3.6	Turn-Off Command	34
5.3.7	Calibrate PO2 Command	34
5.3.8	Alarm and Error messages	35
5.3.9	Advanced Options	36
5.3.10	Color Blind Code	37
5.3.11	Flip orientation	37
5.4	ADV (Automatic Diluent Valve)	38
5.5	Manual supplemental oxygen valve	38
5.6	Manual supplemental diluent valve	38
5.7	DSV (Dive Surface Valve)	38
6	Controller	39
6.1	Overview	39
6.2	Functionality	40
6.3	DiveCAN® Architecture	41
6.4	Turning on the controller	42
6.5	Left and right buttons	42
6.5.1	Left (MENU)	42
6.5.2	Right (SELECT)	43
6.5.3	Overview of the button functions	43
6.6	The main display	44
6.6.1	The Top Row	45
6.6.2	The Center Row	47
6.6.3	The Bottom Row	48
6.7	Info Screens	50
6.8	Notifications	58
6.8.1	Types of Notifications	58
6.8.2	Vibration Alerts	59
6.8.3	List of primary notifications	59
6.9	Compass	62
6.9.1	Mark Heading (Compass)	63
6.10	Air Integration	63
6.11	Menus	64
6.12	Menu structure	65
6.13	Menu reference	66
6.14	Turn Off	66
6.15	Calibrate (calibration of the O2 sensors)	66
6.15.1	External PO2 monitoring	69
6.15.2	Checking calibration during a dive	69
6.16	End Dive	70
6.17	Switch Setpoint	70
6.18	Select Gas	71
6.18.1	Classic Style Select Gas	72
6.18.2	New Style Select Gas	72
6.19	Switch CC/BO (Between Closed and Open Circuit Bailout Mode)	73
6.20	Dive Setup	74



6.20.1	Edit Low SP (Low Setpoint)	74
6.20.2	Edit High SP (High Setpoint)	74
6.20.3	Define Gas	75
6.20.4	Define Gas (New Style)	76
6.20.5	Deco Planner	77
6.20.6	Conserv.	80
6.20.7	NDL Display (GF99, CEIL, NDL, @+5 or Δ+5 display)	80
6.20.8	Brightness	81
6.20.9	Vibration On/Off	81
6.20.10	Test Vibration	81
6.21	Dive Log	82
6.21.1	Display Log / Edit Log	82
6.21.2	O2 Cal. History	83
6.21.3	Next Log	83
6.21.4	Restore Mode	83
6.21.5	Delete All Logs	84
6.22	Start Bluetooth	84
6.23	Reset Stack Time	84
6.24	Setpoint -> .19	84
6.25	System Setup	85
6.25.1	Mode Setup (Overview)	85
6.25.2	Salinity (Mode Setup)	85
6.25.3	Low and High Setpoints (Mode Setup)	86
6.25.4	Deco Setup (Overview)	86
6.25.5	Conserv. (Deco Setup)	86
6.25.6	Last Stop (Deco Setup)	86
6.25.7	NDL Display (Deco Setup)	87
6.25.8	Mini NDL Display (Deco Setup)	87
6.25.9	Clear Cntr (Deco Setup)	87
6.25.10	AI Setup (Overview)	88
6.25.11	BO Gases	89
6.25.12	CC Gases	89
6.25.13	O2 Setup (Overview)	89
6.25.14	Cal. FO2 (O2 Setup)	89
6.25.15	Sensor Disp (O2 Setup)	90
6.25.16	O2 Cal. History (O2 Setup)	90
6.25.17	Auto Setpoint Switch	90
6.25.18	Alerts Setup	91
6.25.19	Display Setup (Overview)	91
6.25.20	Depth Units (Display Setup)	91
6.25.21	Temp. Units (Display Setup)	91
6.25.22	Brightness (Display Setup)	92
6.25.23	Altitude (Display Setup)	92
6.25.24	Flip Screen (Display Setup)	93
6.25.25	Compass (Overview)	93
6.25.26	Compass View (Compass)	93
6.25.27	Calibrate (Compass)	94
6.25.28	True North Declination (Compass)	94



6.25.29	System Setup (Overview)	95
6.25.30	Date (System Setup)	95
6.25.31	Clock (System Setup)	95
6.25.32	Unlock (System Setup)	95
6.25.33	Log Rate (System Setup)	96
6.25.34	Reset to Defaults (System Setup)	96
6.25.35	Advanced Config (Overview)	96
6.25.36	System Info (Advanced Config)	97
6.25.37	Battery Info (Advanced Config)	97
6.25.38	Regulatory Info (Advanced Config)	97
6.25.39	Main Color (Advanced Config 1)	98
6.25.40	Title Color (Advanced Config 1)	98
6.25.41	End Dive Delay (Advanced Config 1)	98
6.25.42	Bat Icon (Advanced Config 1)	98
6.25.43	Gas Select (Advanced Config 1)	99
6.25.44	Advanced Config 2 (PO2 Limits)	99
6.25.45	Advanced Config 3 (Button Sensivity)	99
6.25.46	Advanced Config 4 (Stack Timer)	100
6.26	Bus Devices	100
6.26.1	SRI Petrel (Bus Devices)	101
6.26.2	SRI SOLO (Bus Devices)	101
6.27	Changing the battery	102
6.27.1	Battery Type Selection	102
6.27.2	Behavior on Battery Change	103
6.28	Firmware Update and Log Download	104
6.28.1	Shearwater Cloud Desktop	104
6.28.2	Shearwater Cloud Mobile	106
7	Checklist prior to diving	108
7.1	Preparations on land	108
7.2	Shortly prior to diving	109
7.3	Shortly after entering the water	109
8	Diving	110
9	After the Dive	110
9.1	Transportation	110
10	Cleaning	111
10.1	“Quick” Cleaning	111
10.2	“Complete” Cleaning	111
11	Storage	112
12	Maintenance	113
12.1	General Care	113
12.2	Maximum Service Life	113
12.3	Approved care products	113
12.4	Care Intervals	114
12.4.1	Prior every dive	114
12.4.2	After every dive	114
12.5	Maintenance Intervals	114
12.5.1	Every 12 months	115
12.5.2	Every 24 months	115
12.5.3	Every 60 Months	115



## 1.1 Revisions and changes in documentation



Revision	Description	Author
3.00	JJ-CCR Rebreather (DiveCAN®) - CE Edition Version 3.00 for Shearwater Petrel 3 controller with firmware v95.	Dietmar Inäbnit
3.01	Updated: 4.14 Rebreather safety mouthpiece RBSM, 1.3 UKCA symbol, 3.2 ISO standards, minor language changes and typos.	Marcus Runeson
3.02	Clarifying 4.14, added correct force when mounting the RBSM, 165N.	Marcus Runeson
3.03	Updated section 4.6, added information about counterlung dump-valve. Added	Marcus Runeson
3.04	Added Heliox as an diluent alternative	Marcus Runeson

## 1.2 Manufacturer



The JJ-CCR Rebreather is proudly manufactured in Denmark by:

JJ-CCR ApS, Dyrlevvej 11, 4720 Presto / [www.jj-ccr.com](http://www.jj-ccr.com)

## 1.3 Regulation and standards



The JJ-CCR DiveCAN rebreather is compliant with EU and UK legislation:

Council Regulation (EU) 2016/425 on Personal protection equipment, PPE. (Class III device)

Harmonized standards	Description
EN ISO 14143:2013	Respiratory equipment - Self-contained re-breathing diving apparatus  The JJ-CCR does not meet the requirements of EN 14143 section 5.6.1.4 (Hydrostatic imbalance test) with a pitch of -90 degrees (Vertical head down position).
EN 1809:2014 +A1 2016	Diving equipment - Buoyancy compensators - Functional and safety requirements, test methods.



## 1.4 EC type examination



Notified Body	Adress	Notified body number
SGS Fimko Oy	Takomotie 8, FI-00380 Helsinki, Finland	0598
SGS UK Ltd	Rossmore Business Park, Inwardy Way, Ellesmere Port, Cheshire CH65 3EN, UK	0120

## 1.5 EU Declaration of Conformity



The latest manufacturers Declaration of Conformity can be downloaded from the JJ-CCR website:

<https://jj-ccr.com/downloads/>

## 1.6 Risks against which the PPE is intended to protect



The JJ-CCR rebreather is a respiratory protective device intended for diving purposes only. The JJ-CCR rebreather make it possible to supply the user with a breathable gaseous mixture under foreseeable conditions of use and taking account in particular of the maximum depth of immersion.

## 2 Introduction

Congratulations on purchasing the JJ-CCR Rebreather. We are certain that you will experience many unforgettable dives using this equipment.

The development and testing of the JJ-CCR Rebreather started back in 2006. During this period the equipment was able to demonstrate exceptional reliability over more than 1500 diving hours at a wide range of locations around the world prior the first public release.

The product development philosophy is aligned with the following criteria:

- Strict application of the KISS principle: "Keep It Simple Stupid".
- The Rebreather must be extremely solid, versatile and reliable.
- The Rebreather must be very simple to use, maintain and service.
- The use of easy to obtain parts, enabling on-site repairs at any time.
- The support of a wide range of cylinder sizes without requiring any special adjustments to the equipment.
- The supply of fully operational equipment and not basic equipment with numerous different options.
- The equipment must be configured to include a very high level of redundancy. For example, separate batteries for the controller, HUD and solenoid. No batteries are permitted within the circuit. And it must be possible at all times to manually operate the Rebreather in the event of the controller failing.
- The use of simple and above all reliable electronics. No use of any high tech gimmicks and strict avoidance of an "autopilot effect". The diver retains full control of the Rebreather and not vice versa.
- Availability of scientific test records in order to verify the equipment performance.
- Always on the search for new ways of further improving the equipment.

### 3 JJ-CCR overview



#### 3.1 JJ-CCR Scope of functionality



- Highly robust aluminium housing to which it is possible to secure up to 4 diving cylinders (2 – 12 litre) using conventional cylinder belts.
- Self-filling soda lime canister (axial).
- Heavy duty stand.
- Integrated handle.
- Back-mounted counter lungs.
- Redundant power supply: One battery for the controller, one battery for the HUD and two parallel batteries for the solenoid. None of the batteries are integrated into the circuit.
- Integrated ADV (Automatic Diluent Valve).
- DSV (Dive Surface Valve).
- Manual supplemental O<sub>2</sub> and diluent valves with the option of feeding in external gases.
- Independent HUD (Head Up Display) with real-time display of PO<sub>2</sub> for all three oxygen sensors.
- Reliable controller with an integrated multi-gas decompression computer (based on the Shearwater Petrel 3).

## 3.2 Technical specifications

Dimensions	70 cm x 40 cm x 26 cm including the handle
Weight	34.2 kg – Ready for operation with 2 x 3 litre cylinders 19,8 kg – Without cylinders and soda lime
Soda lime canister	<p>Type: Axial</p> <p>Soda lime: Average 2.5 kg (Sofnolime 797)</p> <p>Running time: 180 min with dive profile (40 m) 180 min with dive profile (100 m)</p> <p>Dive profile: 40 min at 40 m, 5 min at 15 m, 9 m for the remaining time</p> <p>Dive profile: 10 min at 100 m, 1 min at 39 m, 1 min at 36 m, 2 min at 33 m, 2 min at 30 m, 2 min at 27 m, 3 min at 24 m, 4 min at 21 m, 4 min at 18 m, 6 min at 15m, 7 min at 12 m, 10 min at 9 m, 6 m for the remaining time</p> <p>Test parameter: 40 l/min air, 1.6 l/min CO<sub>2</sub>, 4 °C water temperature</p> <p>Used diluent: 40 m - Air 100 m - Trimix 11/65</p>
Soda lime	The only supported soda lime is: Sofnolime® 797 manufactured by Molecular Products.
Oxygen Cylinder	3 Liter steel cylinder (200 bar)
Diluent Cylinder	3 Liter steel cylinder (200 bar)
On board gas duration	<p>Oxygen: The on board oxygen supply will last 252 minutes, if the diver consumes 1.78 liter of oxygen per minute.</p> <p>3 liter x 200 bar = 600 liter - 25% reserve = 450 liter</p> <p>Diluent: The duration depends on the depth and activity of the diver.</p> <p>3 liter x 200 bar = 600 liter</p>
Batteries	<p>1 x 1.5v Lithium (Energizer Ultimate) for the controller</p> <p>1 x 3.6v Lithium (SAFT LS14500) for the HUD</p> <p>2 x 9v block lithium (Parallel operation for the solenoid)</p>
Volume of the counter lungs	8 litres
Maximum application depth	<p>Max. 40 m with air as diluent</p> <p>Max. 100 m with Trimix or Heliox as diluent</p> <p>Warning: Dives exceeding a depth of 100 m are associated with numerous additional risks</p>
Purity of the gases	<p>Purity of all breathing gases according to EN 12021:2014</p> <p>Air: EN 12021:2014</p> <p>Oxygen: EN 12021:2014, &gt;99.5% (medicinal oxygen)</p> <p>Helium: EN 12021:2014, &gt;99.996</p>
Atmospheric pressure range	800 – 1050mbar

1 <sup>st</sup> stage "oxygen"	CE Edition, Connection: EN 144-3 (M26x2) medium pressure: 7.0 to 7.5 bar International Edition, Connection: EN 144-3 (M26x2). ISO 12209:2013, (DIN 5/8") are provided separately. Medium pressure: 7.0 to 7.5 bar
1 <sup>st</sup> stage "diluent"	CE Edition, Connection: ISO 12209:2013, (DIN, 5/8") medium pressure: 9.0 to 10.0 bar International Edition, Connection: ISO 12209:2013 (DIN, 5/8"). Medium pressure: 9.0 to 10.0 bar
Oxygen control	Two oxygen setpoints (low and high). Can be switched as many times as required, also changeable under water.
Oxygen setpoint range	From 0.4 to 1.5 bar (low and high)
Oxygen warnings	Low 0.4 bar High 1.6 bar
Oxygen sensors	3 galvanic cells (type: R17JJ-CCR) - Output: 9-13 mV
Operating temperatures	When diving: +4°C to +34°C Short-term (air): -10°C to +50°C Long-term (storage) +5°C to +20°C

### 3.2.1 Vertical head down position

The JJ-CCR does not meet the requirements of EN 14143 section 5.6.1.4 (Hydrostatic imbalance test) with a pitch of -90 degrees (Vertical head down position). A vertical head down position during a dive is an extremely unusual position for a diver and normally never used when not absolutely necessary. Within a vertical head down position an unintentional activation or freeflow of the ADV can possibly occur. To avoid it when the diver is forced to a vertical head down position they can close the in line shut-off valve on the ADV and use the manual diluent adding valve to maintain an optimized loop.

### 3.2.2 Temperature conditions

The operating temperature for the JJ-CCR is between a minimum of 4° Celsius, and a maximum of 34° Celsius. Operation at temperatures outside of this range may lead to unreliable function.

### 3.2.3 Work rates

The JJ-CCR is intended for use on dives involving low to moderate work rates (E.g. normal recreational and technical diving activities). Although it is capable of sustaining divers operating with high work rates, this is not its intended purpose. At higher work rates the divers needs to take into account a reduced endurance. This is caused by a higher oxygen consumption and a higher CO<sub>2</sub> production which will reduce the running time of the soda lime. Additionally the diver needs to take into account, that a higher work rate can have an impact on the decompression and some additional safety margin should be added. Each body of course is different and reacts differently. Therefore it is not possible to specify exact numbers.

### 3.2.4 High-pressure oxygen

The JJ-CCR uses high pressure oxygen as one of its supply gas mixtures. The related parts has been cleaned and prepared specifically for use with high-pressure oxygen. The diver must taken special care. Especially when filling the oxygen cylinder. Very important is a proper maintenance and oxygen-compatible cleanless for all components exposed to high-pressure oxygen. Service and/or repair work for components exposed to high-pressure oxygen must be carried out by the manufacturer or by a service centre approved by JJ-CCR ApS. Failure to comply with these instructions could lead to an oxygen fire and may cause serious injury or death.

### 3.2.5 Expected inspired gas concentrations

The oxygen setpoint range of the JJ-CCR is from 0.4 to 1.5 bar (low and high). The setpoint range creates breathing gas mixture representing an inspired oxygen partial pressure between 0.4 bar and 1.5 bar. The default setpoints are 0.7 (low) and 1.3 (high) and they are user selectable within the listed setpoint range. The oxygen fraction of the mixture depends upon depth and set point. The following table shows the oxygen and nitrogen fraction with diluent "Air" and setpoint 0.7 and 1.3 to a depth of 50 meters.

Depth (m)	Abs. Pressure (bar)	Setpoint	PO2 (bar)	O2 (%)	ppN2 (Bar)	N2 (%)
0	1.0	0.7	0.70	70	0.3	30
3	1.3	1.3	1.3	100	0	0
6	1.6	1.3	1.3	81	0.3	19
10	2.0	1.3	1.3	65	0.7	35
20	3.0	1.3	1.3	43	1.7	57
30	4.0	1.3	1.3	32	2.7	68
40	5.0	1.3	1.3	26	3.7	74
50	6.0	1.3	1.3	21	4.7	79

The nitrogen fraction will vary depending upon the selected diluent for a dive. To reach the maximum operating depth of 100 meters a trimix or heliox diluent is required. Diving deeper than the maximal recreational depth of 40 meters requires additional training, increases the over all risk and should only be carried out by trained divers.

### 3.2.6 Visibility

During a dive it is essential that the diver can read the information from the setpoint controller display and HUD. Therefore the JJ-CCR should only be used when the visibility in water exceeds approximately 30 centimeters. Using the JJ-CCR in visibility conditions that prohibit viewing of the setpoint controller display and HUD poses increased risks of operation.

### 3.2.7 Use of high oxygen content gases

CNS = Central Nervous System Oxygen Toxicity. Oxygen toxicity is a combination of oxygen pressure and time. The training for the JJ rebreather will cover CNS oxygen toxicity and the NOAA exposure limits.

Prolonged exposure to oxygen in excess of 0.5 bar can lead to pulmonary toxicity, affecting the whole body. Pulmonary toxicity is tracked using Oxygen Toxicity Units, known as OTUs for short. One OTU is earned by breathing 100% oxygen at one bar for one minute. The most conservative limit sets a maximum of 300 OTUs per day for multi day diving trips.

### 3.2.8 Potential long term health effects

There are no long term studies available for using a rebreather. It is the responsible of the diver to inform himself of the consequences of CNS, OTU's and the effect of decompression, emerged in water.

## 4 Assembly of the JJ-CCR



This chapter deals with the basic assembly of the JJ-CCR Rebreather. The equipment is fully assembled at the time of delivery. This chapter is primarily intended to show how the basic assembly takes place. At the same time, it acts as a guideline for correctly reassembling the equipment if it proves necessary to disassemble it for any reason (e.g. transportation for a dive trip).

### 4.1 Base unit



The base unit of the JJ-CCR consists of a highly stable aluminium housing. The guide rails shown in the image hold the selected diving cylinders in the correct position and they are also used to attach the cylinder belts.



On the front side it is possible to see two screw retainers and a tube on both the right and left hand side respectively.



The following image shows how the screw (lock screw M8x30) is inserted in the screw retainer. Both screw retainer openings are arranged such that an unintentional loosening of a connection will not result in the base unit falling off. The plastic section of the screw forms a galvanic partition between the aluminium of the base unit and the rustproof steel of the screw. This prevents corrosion. The wing, counter lung and back plate are secured on the screws later.

## 4.2 Handle ●●●



The following image shows the handle, which is screwed into the two tubes on the base unit. The handle facilitates easy lifting of the JJ-CCR under all circumstances. The two tubes can be used for an additional trim weight. Important: Regardless of whether trim weights are used in the tubes or not, the overall trim of the JJ-CCR will not change! The only difference is the required quantity of lead on the diver's lead belt.



It is possible to use two types of trim weights. One can either opt for lead shot or lead bars. If lead shot is used then it is first necessary to insert a small piece of sponge into the tubes. This prevents the lead shot from falling out. At the same time, the sponge allows the water to run out.

## 4.3 Stand ●●●

The heavy duty stand is secured to the base plate of the base unit with 4 lock screws. The stand prevents the JJ-CCR from falling and can also be used as a fastening point for stages, wheels, buoys, etc. whilst diving.



### 4.3.1 Attaching the stand to the base unit ●●●



When attaching the stand it is first necessary to insert the base plate into the base unit from above. Before inserting the base plate it is necessary to ensure that the sealing surfaces of the base unit are clean. Carefully check the two base plate O-rings and re-grease these if necessary. When doing so, do not use excessive grease but simply apply a light coating. It must be possible to insert the base plate without applying force and without excessive effort.



During the next step the four lock screws are inserted into the base plate. Afterwards, attach the two blocks. An arrow is marked on the base unit and a notch is visible on the block. These serve to ensure the correct alignment of the stand. The stand is now secured. Important: Do not tighten the four nuts yet because it is first necessary to align the stand correctly. The stand is properly aligned if the arrow on the base unit points precisely to the notch in the block. It is now possible to tighten the self-locking nuts. The following image shows the stand correctly attached.

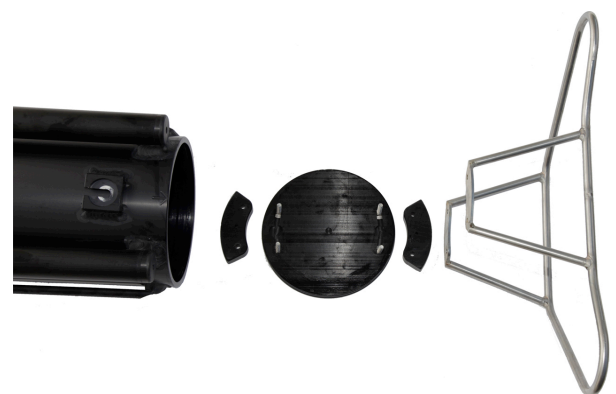

All parts are shown once again here in overview.

## 4.4 1<sup>st</sup> stages and hoses ●●●

The next assembly step concerns the 1st stages and hoses (low pressure and high pressure). When developing the JJ-CCR, extensive value was placed on clear and simple hose guidance. A further primary objective was to ensure that the equipment was fitted with the minimum possible number of hoses.



The 1st stage with the EN 144-3 (M26x2) connection and the green pressure gauge is used for oxygen. A low pressure hose line delivers the oxygen for the solenoid and the second hose is connected with the manual supplemental oxygen valve. The oxygen pressure relief valve triggers if the medium pressure rises to 10 bar, and thereby prevents the hoses from rupturing if, for example, icing up should occur. The 1st stage with the ISO 12209:2013 (DIN 5/8") connection and the black pressure gauge is used for diluent. From the 1st stage a hose goes to a small 3-way manifold. Here, the three hoses are connected with the ADV, manual supplemental diluent valve and wing inflator. The diluent pressure relief valve triggers if the medium pressure rises to 15 bar, and thereby prevents the hoses from rupturing if, for example, icing up should occur.



The image to the left shows how the first two stages are connected to the diving cylinders. Arrangement of the high pressure and low pressure hoses differs! It is very important to ensure that the hoses are arranged as shown in the image!

The image to the right shows the correct position of the 3-way manifold, which must lie flush with the housing.

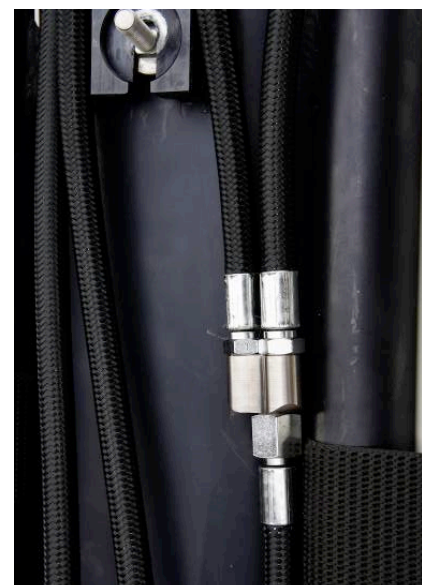

## 4.5 Wing ●●●



The next assembly step concerns the wing. The JJ-CCR Rebreather is supplied with one wing, which is optimally tailored to the equipment and has been specially developed for it. The following image shows the correct hose arrangement. The two high pressure hoses must be fed through the lower opening in the wing. All hoses from the diluent must run through the upper opening. In the case of the oxygen, it is only necessary to run the hose for the manual supplemental oxygen valve through the upper opening.

The special position of the pressure gauges is advantageous for a number of reasons. During the pre-dive check they are very easy to read, whilst their position is completely out of the way during the dive. If, during a dive, it is necessary to check the cylinder pressure (oxygen or diluent) then it is very easy to reach both pressure gauges and to pull these forward.

## 4.6 Back-mounted counter lungs (BMCL) and dump valve ●●●

Next, the back-mounted counter lungs are attached. The holes permit attachment of the back-mounted counter lungs at two different heights.



The pull dump knob must be fed through the elastic loop on the wing.

**ATTENTION:** Never attempt to lift the equipment using the ADV, T-piece or loop hoses. This can cause serious damage to the counter lungs!



The dump valve has two selectable positions:

**Pre-dive mode** – used for efficient over-pressure testing.

To engage pre-dive mode, press the valve inward and rotate it clockwise until it locks. In this mode, the green indicator ring will not be visible.

**Dive mode** – the normal operating position during the dive.

To engage dive mode, rotate the valve counter-clockwise. The valve will spring outward, and the green indicator ring at the base will be clearly visible. In this position, the valve maintains the internal loop pressure below the maximum allowable over-pressure.

In both positions, the valve can be manually overridden at any time by pulling the knob mounted on the wing.

**IMPORTANT:** Always check the correct position of the dump-valve during your pre-dive routine.

## 4.7 Backplate and harness ●●●

The counter lung must be fastened to the harness. The top section of the counter lung is fitted with two fastening straps with Velcro for this purpose. The Velcro must be opened and one strap must be fed between the harness and the shoulder padding. The second strap is then used in order to close the Velcro fastening. The straps with Velcro must not be placed over the shoulder padding!



The following diagram shows the correct fastening of the counter lung to the harness.



Counter lung    Harness    Shoulder padding

A washer and wing nut are attached to the backplate. From time to time it is necessary to check whether the wing nut requires tightening, or if it has loosened at all.

### 4.7.1 Adjust the harness

The harness is supplied fully assembled together with the back plate. However, it is essential that the harness is adjusted to the physical dimensions of the diver. The JJ-CCR Rebreather must always sit as high as possible on the diver's back. It is also necessary to ensure that the equipment sits as tight to the back as possible.

- The JJ-CCR Rebreather is supplied with an adjustable harness. This enables very simple adjustment when putting on, and it is also possible to make underwater re-adjustments if necessary.
- A poorly adjusted harness can have an extremely negative effect on the comfort of the wearer during a dive.

The following images show both correct and incorrect adjustment. The right hand image shows the harness following incorrect adjustment, with the equipment sitting too low on the back. The left hand image shows the harness following correct adjustment, with the equipment sitting in the correct position the diver's back.



CORRECT



INCORRECT

## 4.8 Connecting the supplemental valves

The JJ-CCR comes with two supplemental valves. The oxygen valve enables the manual supply of oxygen via the t-piece into the breathing circuit. The diluent valve enables the supply of diluent via a second connection on the ADV into the breathing circuit.

Connect the low pressure oxygen hose (inflator connection) with the manual supplemental oxygen valve. It is recommended that both hoses be fed to the manual supplemental oxygen valve through the D-ring (see image). In this way the supplemental oxygen valve always remains in the same position, even during a dive.

Connect the longest low pressure diluent hose (inflator connection) with the the manual supplemental diluent valve. It is recommended that both hoses be fed to the manual supplemental diluent valve through the D-ring (see image). In this way the supplemental diluent valve always remains in the same position, even during a dive.



## 4.9 Connecting the ADV



Connect the shortest low pressure hose with the in-line shut-off valve from the 1st stage (diluent) with the ADV.

Never use any form of tool for this action! It is entirely sufficient for the connection to be hand-tight.

## 4.10 Connecting the wing inflator



The hose with the inflator connection is connected to the inflator from the wing and the complete assembly is then pushed through the inflator retainer on the harness. In this way the inflator always remains in the same position, even during a dive.

#### 4.11 Soda lime canister (axial)



The JJ-CCR Rebreather is supplied with an axial soda lime canister.



1. Take a water-resistant dust filter and place it in the base of the soda lime canister. Ensure that the base is completely covered and that no gaps are visible at the edge.



2. Fill the soda lime canister until approx. half full with soda lime. Knock lightly all around the outside of the canister, in order to level out the soda lime or compact it.



3. Fill the soda lime canister once more until you can see clearance of 4-5 mm. Knock lightly all around the outside of the canister, in order to level out the soda lime or compact it. Now place the second dust filter on top of the soda lime.



4. Place the spring pressure plate on the dust filter and tighten the nut until it is hand-tight. Then knock lightly all around the outside of the canister, in order to level out the soda lime or compact it. The nut will usually loosen a little during this process and must be hand-tightened again afterwards. **ATTENTION:** Please do not tighten the nut excessively as this can damage the soda lime canister. The soda lime canister is correctly filled if shaking it does not result in noise being heard from the soda lime.

**IMPORTANT:** Soda lime that has already been used must never be used for another dive.

## 4.12 Soda lime canister (radial) ●●●

FOR INTERNATIONAL EDITON ONLY: The radial soda lime canister is available as an option to the JJ-CCR.



- The radial soda lime canister must be filled extremely carefully and it is essential to ensure that the soda lime is correctly compacted.
- In order to fill the radial soda lime canister correctly, take a minimum of 10 minutes for this action.



A water-resistant dust filter is located on the inner tube. This prevents dust from the soda lime from entering the inhalation side of the breathing circuit. In order to replace the dust filter it is possible to simply screw out the entire inner tube. The dust filter is attached by three O-rings.

The radial soda lime canister must be filled in stages. At each stage, approx. 5 – 7 cm of soda lime should be added. Each time soda lime is added this must then be compacted. This is most simply carried out by knocking right around the edge of the black section of the soda lime canister. Fill the soda lime canister until you can see clearance of 4-5 mm. Knock lightly all around the black section of the canister, in order to level out the soda lime or compact it.



Never knock on the top section (= grate) of the soda lime canister in order to compact the soda lime. This could damage the soda lime canister.

**IMPORTANT:** Soda lime that has already been used must never be used for another dive.

Insert the spring pressure plate and tighten the nut until it is hand-tight. Then knock lightly all around the black section of the canister, in order to level out the soda lime or compact it. The nut will usually loosen a little during this process and must be hand tightened again afterwards. The pressure plate must be flush with the soda lime canister. The soda lime canister is correctly filled if shaking it does not result in noise being heard from the soda lime.

### 4.13 Lid assembly ●●●

The lid and the soda lime canister are screwed together with a quarter turn and sealed with an O-ring. This O-ring must be checked carefully prior to assembly! Never tighten the soda lime canister excessively!



Before placing the lid with the soda lime canister into the aluminium housing, the two O-rings must be very carefully checked and re-greased if necessary. When doing so do not use excessive grease but simply apply a light coating. This is a very important point as it is otherwise possible that the rebreather may leak which may cause serious risk to the user and severe damage to the rebreather.

**A leakage in this area will most likely be discovered during the positive and negative pressure test!**



Align the lid such that the stud and the hole in the aluminium housing line up with each other.



Push down on the stud and start to push the lid slowly down with the soda lime canister.



The correct position has been attained once the stud pokes out of the hole in the aluminium housing.



Push both the HUD and the controller through the handle.



Now connect the oxygen low pressure hose. **Only tighten until hand-tight!**



Take both breathing hoses and feed these through the handle. Afterwards, your equipment should be in position as in the image above.

Note: The breathing hose in the centre of the lid is for the inhalation side and is always connected to the ADV!



Connect the breathing hoses to the T-piece and ADV. It is not possible to connect these incorrectly because the two connection threads are different. The connection thread on the inhalation side (ADV) is clockwise, whilst the thread on the exhalation side (T-piece) is anti clockwise.

**ATTENTION: Never attempt to lift the equipment using the ADV or T-piece. This can cause serious damage to the counterlungs!**

#### 4.14 Breathing hose with DSV (Dive Surface Valve)

It is now possible to connect the breathing hose with the DSV (Dive Surface Valve).



Before connecting the breathing hose it is always necessary to check that both check valves are operating correctly!

The arrow on the DSV indicates the flow direction of the breathing circuit. It is not possible to connect the breathing hose incorrectly because the two connection threads are different. The connection thread on the inhalation side (ADV) is clockwise, whilst the thread on the exhalation side (T-piece) is anti clockwise.

#### Rebreather safety mouthpiece



The Rebreather Safety Mouthpiece (RBSM) is included, factory-fitted, as standard with all new JJ-CCR rebreathers. (The RBSM is also available to retro-fit to older units). The tie must be fitted to the DSV with the correct force of 165N, using a cable tie gun. Do not exceed this force.

The RBSM head strap can be fitted to the mouthpiece valve assembly which offers additional support by holding the mouthpiece towards the wearer. The strap is particularly useful on long duration dives by minimising the effort needed to retain the mouthpiece in position, thereby reducing jaw fatigue. A head strap may also help retain the position of the mouthpiece if the diver becomes unconscious.

Warning, Although the head strap offers some degree of support to the wearer, there can be no guarantee that it will hold the mouthpiece in the mouth of an unconscious diver.

Warning, If a head strap is used the diver must consider its consequences as it could hinder certain operations while in use i.e. draining water from the mouthpiece assembly and bailout drills, both of which may require the wearer to move the mouthpiece away from the face. As with any change to equipment configuration, relevant drills should be reviewed and practiced before diving with it.



Take the HUD and feed it through the two red O-rings on the breathing hose. Then push it into the retainer on the DSV.

The JJ-CCR Rebreather is now fully assembled and the assembly chapter is hereby complete.

For detailed information on the individual main components of the JJ-CCR Rebreather refer to the respective chapters.

**WARNING:** The equipment is not yet ready for diving! It is always necessary to carry out the pre dive checks in accordance with chapter 7!

## 5 Main components ● ● ●

This chapter provides descriptions of some of the main components of the JJ-CCR Rebreather and also includes a few essential maintenance and care instructions.

### 5.1 Lid ● ● ●



The lid with the three oxygen sensors, solenoid, battery compartment, and connectors for controller and HUD is effectively the brain of the JJ-CCR Rebreather. On the right hand side is the connection for the low pressure oxygen hose to the solenoid. Under the cap engraved with "JJ-CCR" is the battery compartment.

**IMPORTANT:** The lid should always be treated with the utmost care.

#### 5.1.1 Battery compartment ● ● ●

In order to open the battery compartment it is necessary to remove the 10 screws from the battery compartment. The JJ-CCR Rebreather has an extremely low energy consumption. The batteries usually have a lifetime between 6 to 12 months.

A design feature of the JJ-CCR Rebreather is the arrangement of the batteries. As shown in the image, no batteries are integrated into the breathing circuit and the battery compartment is completely sealed. As such battery problems never arise due to increased moisture, which would have been the case within the breathing circuit. Furthermore, the batteries are not exposed to any pressure changes in the battery compartment.



**IMPORTANT:** Only 9 volt block batteries with rounded edges will fit.

Problems with batteries, that may be attributed to severe changes in pressure, are therefore fully excluded with the JJ-CCR Rebreather. Due to the complete sealing of the battery compartment, a fully flooded breathing circuit will also have no effect on the batteries. The two 2 x 9v block lithium batteries are used in parallel for the solenoid. When replacing the batteries please always change both batteries! The current voltage of the batteries can be checked on the status display on the controller. The controller also issues an external battery warning (Low Battery EXT) if the voltage is too low. The 3.6v lithium battery (SAFT 14500) is for the HUD. Please ensure that the battery is inserted correctly into the battery holder. The battery holder is appropriately marked with "+" and "-" signs. It is recommended that the battery for the HUD always be replaced at the same time as both batteries for the solenoid.

### 5.1.2 Oxygen sensors

The JJ-CCR Rebreather uses three JJ-CCR oxygen sensors. The sensors can be exchanged in seconds without the use of a tool.



The three cells are numbered (1, 2 and 3). These numbers can be found adjacent to the connection on the lid and above each cell.

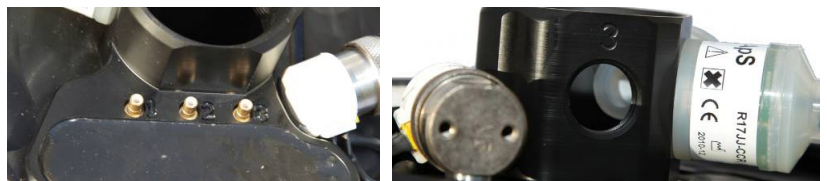

The wiring of the sensors with the connections in the lid must be carried out correctly according to the numbers because the sequence (1, 2 and 3) corresponds with the display in the controller and the HUD.

**IMPORTANT:** Use only sensors of type "R17JJ-CCR"! A sensor marked "PSR-11-39-JJ" is Not a Factory Authorized Sensor. Maximum sensor life is 15 months from date of manufacture but only 12 months of use in the rebreather, so if the cell is kept in the original packaging for 3 months it can then be used for 12 months in the rebreather. Any extra months in the packaging must be deducted from the 12 months of allowed use:

Example 1: JJ-CCR oxygen sensor Manufactured Date 11/18 - Cell is opened from original packaging on 11/18 you can then mark your cell 11/19, one year.

Example 2: JJ-CCR oxygen sensor Manufactured Date 11/18 - Cell is opened from original packaging on 1/19 you can then mark your cell 1/20, one year.

Example 3: JJ-CCR oxygen sensor Manufactured Date 11/18 - Cell is opened from original packaging on 5/19 you can then mark your cell 2/20, you get an additional 3 months from original production date, but not a full 12 months from when you took it out of its original packaging.

### 5.1.3 Solenoid



The JJ-CCR Rebreather uses a special solenoid, which is characterised in particular by its extremely low power consumption. With this solenoid the defective operating state is always in the closed position – this dramatically reduces the potential for oxygen poisoning in the event of a malfunction.

- Service and/or repair work on the solenoid must be carried out by the manufacturer or by a service centre approved by JJ-CCR ApS!

### 5.1.4 Breathing hoses



Two breathing hoses are attached to the lid. The breathing hose in the centre is connected to the ADV and the breathing hose on the edge of the lid to the T-piece. In order to remove the two breathing hoses (refer also to chapter 10.2) it is necessary to remove the hex socket head screw with the washer. Afterwards it is possible to remove both hoses.

The two openings have different diameters and it is therefore impossible to incorrectly insert the breathing hoses when assembling.

## 5.2 Controller



The JJ-CCR Rebreather is supplied with a Shearwater Petrel 3 controller, which contains a multigas (nitrox, trimix, heliox) and multimode (Open and Closed Circuit) decompression computer. The firmware installed on the controller is optimized for the JJ-CCR Rebreather and contains capabilities and functions developed specially for the equipment.

For a detailed description of the controller refer to the chapter 6.

## 5.3 HUD (Head Up Display)

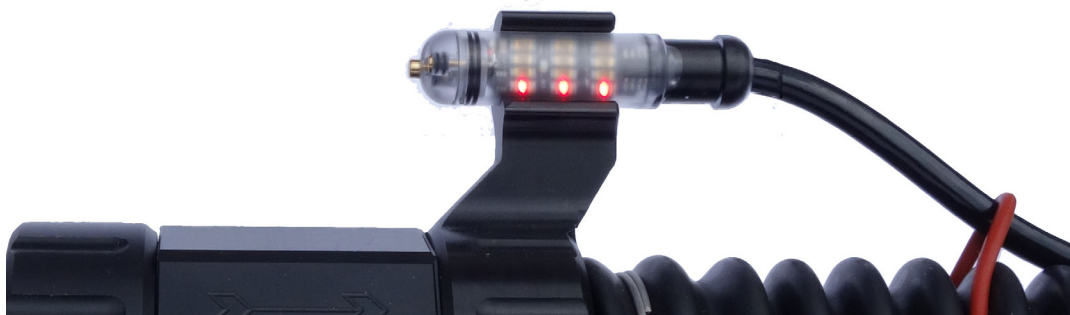

The JJ-CCR Rebreather is supplied as standard with an HUD (Head Up Display). The HUD functions fully independently of the controller. This means that it uses its own DiveCAN® bus, electronic and power supply. The essential features are:

- PO<sub>2</sub> display from 3 oxygen sensors.
- Modified Smither's code blink pattern.
- Bright light emitting diodes with vibrant colors.
- Color-blind blink pattern (optional setting).
- Wet contacts for automatic turn-on.
- DiveCAN® communications interface for robust data transmission and easy upgrades, disassembly and repairs.
- Bright red end-cap LED for buddy warnings.
- Automatic brightness control optimizes viewing in all conditions.
- Red color only used for unsafe PO<sub>2</sub> warnings.

### 5.3.1 Overview

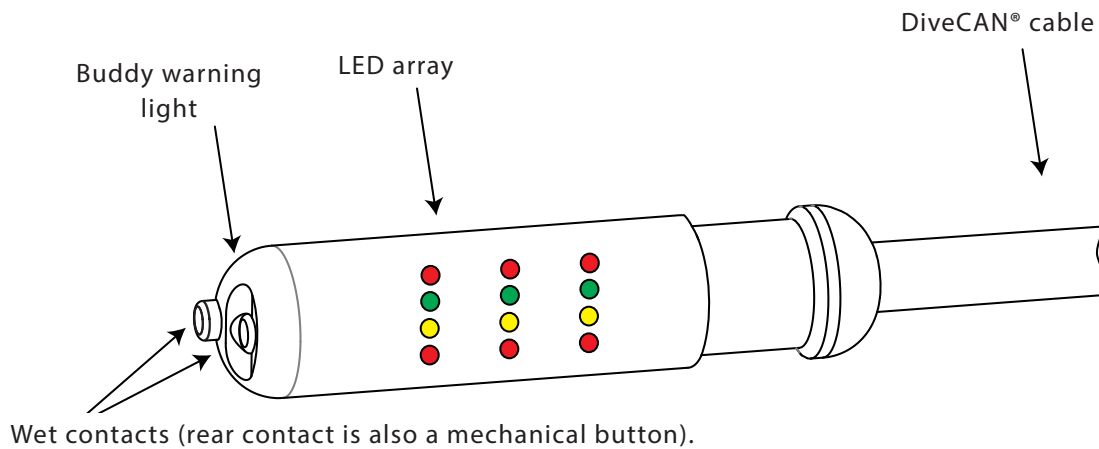

LED array: An array of colored light emitting diodes (LEDs) blink to display PO2. For color-blind users, there is an optional blink pattern that uses position only to display PO2

Buddy warning light: The buddy warning light pulses when PO2 is outside a safe range.

Wet contacts: Wet contacts turn the HUD on automatically when wet. The rear contact is also a mechanical push button for entering commands.

Cable: The DiveCAN® cable provides a robust, disconnectable connection to the rebreather.

The default blink pattern is a modified Smither's code. As alternative a mode color-blind people can be chosen. PO2 is displayed in absolute atmospheres (ata) with a resolution of 0.1 ata. For the purposes of this HUD, this can be considered the same as Bar. i.e. 1 ata ≈ 1 Bar.

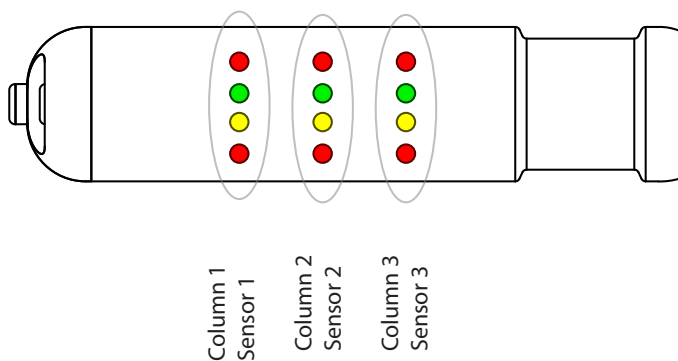

There are four rows of LEDs. Top is red. Next is green, then yellow. Bottom row is red.

Each column displays PO2 from one O2 Sensor

A blinking LED is drawn with lines emanating from it. An LED that is on-steady is drawn solid. An off LED is not drawn.

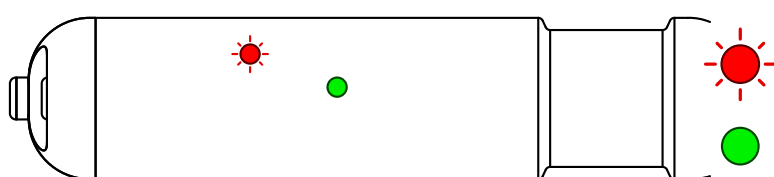

Red LED is blinking

Green LED is on solid

All other LEDs are off

### 5.3.2 PO2 Display ●●●

The default PO2 display is a modified Smither’s code. Blinks of color are used to display PO2. Every 5 seconds a blink cycle begins. The blink pattern depends on the PO2 range:

PO2 Range	HUD Display	Blink Pattern
Above 1.6		Top-red blinks once for each 0.1 above 1.0 e.g. 1.7 = 7 top-red blinks
1.1 to 1.6		Green blinks once for each 0.1 above 1.0 e.g. 1.3 = 3 green blinks
1.0		1.0 = Green and yellow blink once together.
0.4 to 0.9		Yellow blinks once for each 0.1 below 1.0 e.g. 0.7 = 3 yellow blinks
Below 0.4		Bottom-red blinks once for each 0.1 below 1.0 e.g. 0.2 = 8 bottom-red blinks

The modified Smither’s code has some nice attributes that grab attention in abnormal or unsafe situations. A typical rebreather PO2 setpoint will be about 0.7 to 0.8 for the low setpoint, and 1.2 to 1.3 for the high setpoint. Therefore, when the loop is at setpoint, you will expect to see 2 to 3 blinks per 5 second cycle. If the “light density” changes (i.e. you are seeing more or less blinks), then the setpoint is off target. This change in light density can grab your attention even if you have tuned out the blinking of the LEDs. Of course, we recommend paying attention at all times.

If the PO2 falls below 0.4 or rises above 1.6, you will be seeing a lot of red blinking. Since red is not used at all in the normal safe PO2 range, the presence of red is a clear signal that something is wrong.

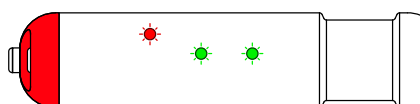

The sole function of the buddy red warning light is to alert that the PO2 is outside the range of 0.4 to 1.6. If any O2 cell is outside this range then the warning light turns on. If the buddy warning light comes on, check your PO2, consult your handset, and deal with the problem.

### 5.3.3 Basic Commands ●●●

Commands are entered by pressing the rear wet contact, which acts as a mechanical push button.

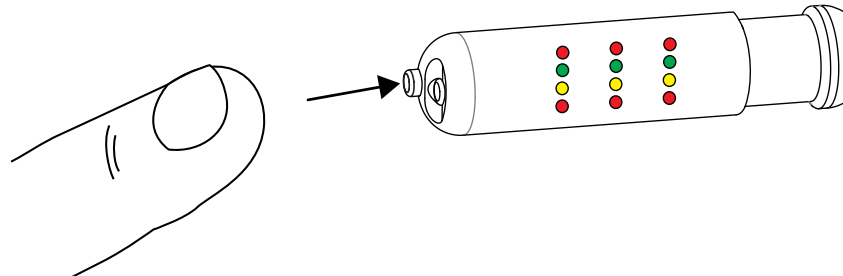

The basic commands are: Turn-on, Turn-off, PO2 Calibration, Enter advanced Menu

### 5.3.4 Turning On ●●●

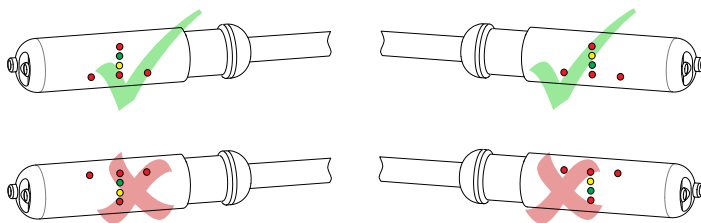

Turn the HUD on by pressing the button once. The HUD will also turn on automatically if the wet contacts detect water.

After turning on, each LED will light up briefly. Use this time to verify that each LED, including the buddy warning light, works properly.

- Do not use the HUD if any LED is not working.

After each LED has been turned on, an “UP” arrow will briefly display. This indicates which orientation the HUD has been set to use (Chapter 5.3.11).

### 5.3.5 Entering Commands ●●●

A Command is entered by:

1. Pushing and releasing the button until the correct command is selected.
2. Holding the button for 3 seconds to confirm the command.
3. The LEDs will then blink twice to show the command was accepted.

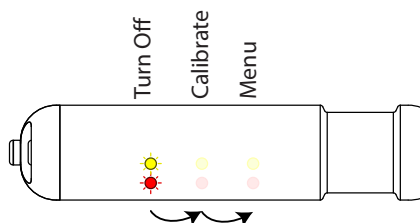

After the first button press, the bottom two LEDs of column 1 will blink. This is “command column 1” or the TURN-OFF command. Each button press advances the command column by one.

When the desired command is blinking, hold the button for 3 seconds to execute the command. The LED column will blink twice as a confirmation. The command will then execute.

- When the wet contacts detect water, the button inputs are disabled. This is to prevent entering commands while diving.
- If the button is not working, try rinsing in fresh water and then ensuring that the wet contacts are dry.

### 5.3.6 Turn-Off Command

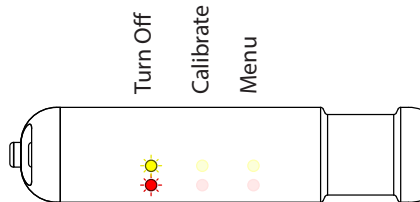

Turn off by holding the button for 3 seconds while on command column 1. The complete turn off sequence is:

1. Press once to enter 1st command column (TURN-OFF).
2. Hold for 3 seconds.
3. While holding, the 1st column LEDs count up. They blink twice to confirm the command.
4. HUD shuts off.

- Turn off the HUD when not in use to save battery power.
- The HUD will turn off by itself after 30 minutes of inactivity.
- However, the HUD will not turn-off if the wet contacts detect the presence of water.
- Ensure the wet contacts are dry before putting the HUD into storage.

### 5.3.7 Calibrate PO2 Command

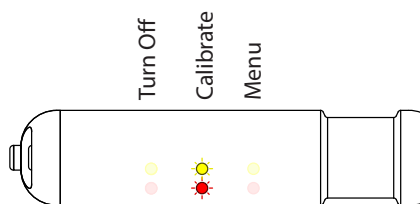

Perform the PO2 calibration by holding the button for 3 seconds while on command column 2.

Calibration of the HUD should take place immediately after calibrating the controller! It is recommended that the HUD and controller always be calibrated at the same time!

The complete calibration sequence is:

1. Open the valve on the oxygen cylinder.
  2. Open the mouthpiece (=CC mode).
  3. Turn on the HUD.
  4. Start the calibration sequence for the controller (Chapter 6.15).
  5. Perform the following steps as quickly as possible, so that you can calibrate the HUD as soon as possible after completion of the controller calibration!
  6. Press once to enter 1st command column (TURN-OFF).
  7. Press again to advance to 2nd command column (CALIBRATE).
  8. Hold for 3 seconds.
  9. While holding, the 2nd column LEDs count up. They blink twice to confirm the command.
  10. The green and yellow LED rows then count up to indicate the calibration is in progress.
  11. Once the calibration completes, the HUD will return to the regular PO2 display.
- The HUD only calibrates at a PO2 of 1.0 ata. This means it assumes pure oxygen is used for the calibration, and it is performed at sea-level.

### 5.3.8 Alarm and Error messages

The following table shows alarm and error messages related to a failed calibration of the oxygen sensors:

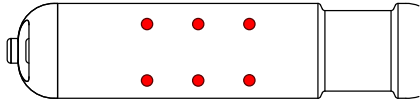
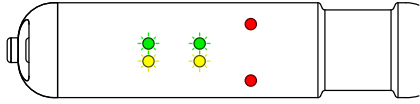
HUD Display	Description	Troubleshooting
 <p>Top and bottom red LEDs on solid</p>	<p>All O2 sensors have failed calibration.</p>	<p>A good O2 sensor is expected to output between 30 mV to 70 mV in pure oxygen at sea-level.</p> <p>A sensor that does not meet these specs fails calibration. Fix the problem (e.g. replace the sensors) and recalibrate.</p>
 <p>Top and bottom red LEDs on solid (1 column)</p> <p>Other columns normal</p>	<p>One O2 sensor has failed calibration.</p> <p>In this case sensor #3 has failed.</p>	<p>It is possible for some sensors to pass calibration, while others fail.</p> <p>This indicates which sensor is faulty.</p> <p>See above for troubleshooting.</p> <p><b>Do not dive unless all sensor are functional!</b></p>

The following table shows alarm and error messages related to a failed DiveCAN® communication:

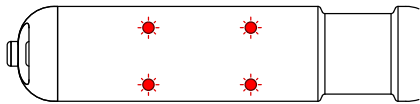
HUD Display	Description	Troubleshooting
 <p>Four corners blinking</p>	<p>No DiveCAN® Communications</p>	<p>Ensure the DiveCAN® cable connector is securely fastened.</p> <p>Contact Shearwater or your rebreather manufacturer for service.</p>

The following table shows alarm and error messages related to low battery voltage:

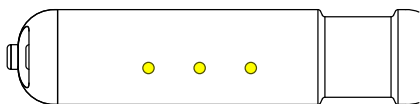
HUD Display	Description	Troubleshooting
 <p>After turn on, the yellow row stays on for 30 seconds</p>	<p>Battery is low and should be replaced</p>	<p>Replace the 3.6 V Lithium Batterie (SAFT LS 14500). Refer to chapter: 5.1.1</p>

### 5.3.9 Advanced Options

There are two options that can be set by the user. 1) Choosing the PO2 blink pattern. 2) Flipping the orientation to the other side of the rebreather mouthpiece.

- Flipping the orientation to the other side of the rebreather mouthpiece makes no sense with the JJ-CCR rebreather, as the HUD holder on the DSV is on the right side. This function is only useable, when somebody connects another DSV oder BOV to the JJ-CCR which allows to attach the HUD to the left side.

1. Turn the HUD on by pressing the button once.
2. Press once to enter 1st command column (TURN-OFF)
3. Press again to advance to 2nd command column (CALIBRATE).
4. Press again to advance to 3rd command column (MENU).
5. Hold for 3 seconds to enter the advanced options menu
6. Once in the advanced options menu, the 1st column will alternately blink the top-red and bottom-red LEDs.
7. Each press advances the option column by one position.
8. Select the option by holding for 3 seconds while the option column is blinking
9. An option column will time-out, returning to the regular PO2 display after 20 seconds of inactivity.  
Also, an additional press when on the last option column will return to the regular PO2 display.

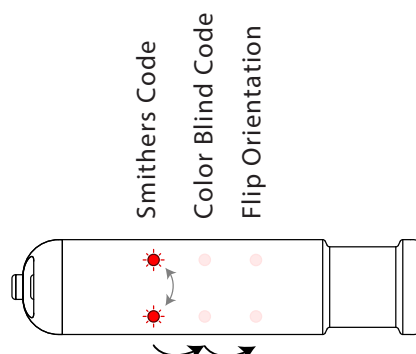

### 5.3.10 Color Blind Code

The optional color blind blink pattern uses positioning of the LEDs to indicate PO2. Every 5 seconds a blink cycle begins. The blink pattern depends on the PO2 range:

PO2 Range	HUD Display	Blink Pattern
Above 1.6		Top row blinks once for each 0.1 above 1.0 e.g. 1.7 = 7 top row blinks
1.1 to 1.6		Upper-middle blinks once for each 0.1 above 1.0 Lower-middle row on solid e.g. 1.3 = 3 upper-middle blinks
1.0		1.0 = both middle rows on solid
0.4 to 0.9		Upper-middle row on solid Lower-middle blinks once for each 0.1 below 1.0 e.g. 0.7 = 3 lower-middle blinks
Below 0.4		Bottom row blinks once for each 0.1 below 1.0 e.g. 0.2 = 8 bottom row blinks

### 5.3.11 Flip orientation

The orientation can be flipped so that the HUD can be positioned on either side of the rebreather mouthpiece.

- Flipping the orientation to the other side of the rebreather mouthpiece makes no sense with the JJ-CCR rebreather, as the HUD holder on the DSV is on the right side. This function is only useable, when somebody connects another DSV oder BOV to the JJ-CCR which allows to attach the HUD to the left side.

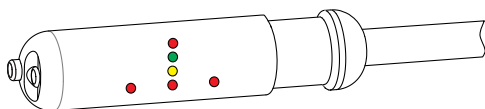

The first image shows the standard HUD orientation on the JJ-CCR rebreather. The HUD is located on the right side of the DSV.

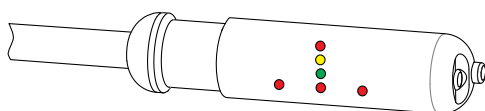

The second image shows the flipped HUD orientation. This allows the HUD to be located on the left side of DSV or BOV.

5.4 ADV (Automatic Diluent Valve) ●●●



The JJ-CCR Rebreather is supplied with an ADV. The ADV works in a similar way to a 2nd stage and supplies additional diluent to the breathing circuit if necessary. This is the case for example if considerable negative pressure exists in the breathing circuit. It is also possible to actuate the ADV manually by pressing down on the membrane cap. The ADV does not require any adjustment.

5.5 Manual supplemental oxygen valve ●●●



The manual supplemental oxygen valve feeds oxygen into the breathing circuit. The longer the button is depressed, the more oxygen is supplied to the breathing circuit. A light press of the button results in a small quantity of oxygen being fed into the circuit, whilst pushing down heavily on the button adds more oxygen. This facilitates very accurate adherence to the desired PO2 when the Rebreather is operated in manual mode. It is possible to remove the connection hose and turn the valve through 180 degrees, in order to connect an external gas supply.

For example: The oxygen cylinder is empty and you have a bailout system with oxygen or another gas and now wish to manually feed this into the breathing circuit.

5.6 Manual supplemental diluent valve ●●●



This valve enables the manual supply of diluent into the breathing circuit. The longer the button is depressed, the more diluent is supplied to the breathing circuit. A light press of the button results in a small quantity of diluent being fed into the circuit, whilst pushing down heavily on the button adds greater diluent. It is possible to remove the connection hose and turn the valve through 180 degrees, in order to connect an external gas supply.

5.7 DSV (Dive Surface Valve) ●●●



The JJ-CCR Rebreather is supplied with a DSV. The JJ-CCR DSV is extremely compact and has a neutral weight in the water. Its movement is very smooth and it is possible to switch between open and closed using one hand. A retainer for the HUD is also integrated into the DSV.

**ATTENTION:** Before connecting the breathing hose with the DSV it is always necessary to check that both shutter valves are functioning correctly. It is also necessary to ensure that the DSV can be opened and closed with ease.

## 6 Controller

The JJ-CCR Rebreather is supplied with a controller, which contains a multigas (nitrox, trimix, heliox) and multimode (Open and Closed Circuit) decompression computer. The firmware installed on the controller is optimised for the JJ-CCR Rebreather and contains capabilities and functions developed specially for the equipment.

### 6.1 Overview



The controller is connected to the JJ-CCR Rebreather lid via a wet pluggable connection. The large-scale, high resolution OLED display is visible on the top.

Somewhat to the right and behind the small hole in the panel is the brightness sensor. This measures the ambient light and automatically adjusts the brightness of the display to the respective ambient light.

One piezo button is situated to the left and one to the right respectively. The complete operation takes place using these two buttons. The piezo buttons used here offer the maximum in flexibility, a long service life and absolute reliability. They cannot catch in the same way as mechanical control buttons and there is no need to clean them in order to maintain their faultless and smooth functionality.

The battery compartment is located on the right hand side. This is very easy to open with a coin. The battery can be replaced by the user.

On the underside (covered by the arm strap retainer) is the opening for the pressure sensor.

The two piezo buttons are also wet contacts. The controller turns on as soon as it comes into contact with water.

## 6.2 Functionality



- High-contrast 2.6" AMOLED display
- Automatic brightness adjustment of the display to the ambient light
- Rugged construction with titanium bezel
- DiveCAN® communications
- A menu system that adapts to diving status
- Powerful vibration alerts
- Use of metric or imperial system
- Programmable depth sampling rates
- Depth sensor calibrated to 130 m / Depth sensor function past 300 m
- Crush pressure rating of 290 m
- Switches on automatically with (depth) pressure, water contact
- High altitude diving mode
- Closed circuit (CC) and open circuit (BO) bailout mode
- 5 CC & 5 BO gases
- Any combination of Oxygen, Nitrogen and Helium (Air, Nitrox, Trimix or Heliox)
- Gases can be added and changed during a dive
- Automatic PO2 set-point switching (configurable)
- Two PO2 set-points, each of which can be set between .5 and 1.5
- Set-points can be changed underwater at any time
- PO2 real-time display of 3 oxygen sensors including "Voting Logic"
- Oxygen sensors mV display
- Oxygen sensors auto-calibration
- Oxygen content for oxygen sensor calibration is adjustable
- Bühlmann ZHL-16C with gradient factors standard
- Optional VPM-B decompression model
- GF values (low and high) and VPM conservatism adjustable by the user
- No lockout for violating deco stops
- CNS Tracking
- Gas Density Tracking
- Full decompression planner built in
- Internal logbook (up to 1000 dive hours)
- Warning in the event of low battery voltage (internal and external)
- Simultaneous wireless pressure monitoring of up to 4 cylinders
- Tilt compensated digital compass with multiple display options
- Display can be rotated through 180 degrees
- Bluetooth Dive log uploading to Shearwater Cloud
- Bluetooth Firmware Updates

### 6.3 DiveCAN® Architecture

DiveCAN® is a digital communications standard developed specifically for rebreathers. The JJ-CCR uses two independent DiveCAN® busses. The handset (controller) is connected via the control bus to the SOLO board (Solenoid and Oxygen controller). The HUD uses the monitor bus and is connected to the Oxygen board (OBOE).

The SOLO and OBOE board are completely independent and each board is powered by its own power supply. The SOLO board power source are the two 9 volt block batteries, where as the OBOE board uses the 3.6 volt SAFT Lithium battery.

Modular design compartmentalizes critical functions for redundancy. For example, the Solenoid and Oxygen board (SOLO) can measure and inject oxygen independently of the handset. If the handset is unplugged or damaged, the SOLO can continue to control loop PO2.

Components (handset, HUD, etc) can be easily removed for travel, repair, backup, and upgrades.

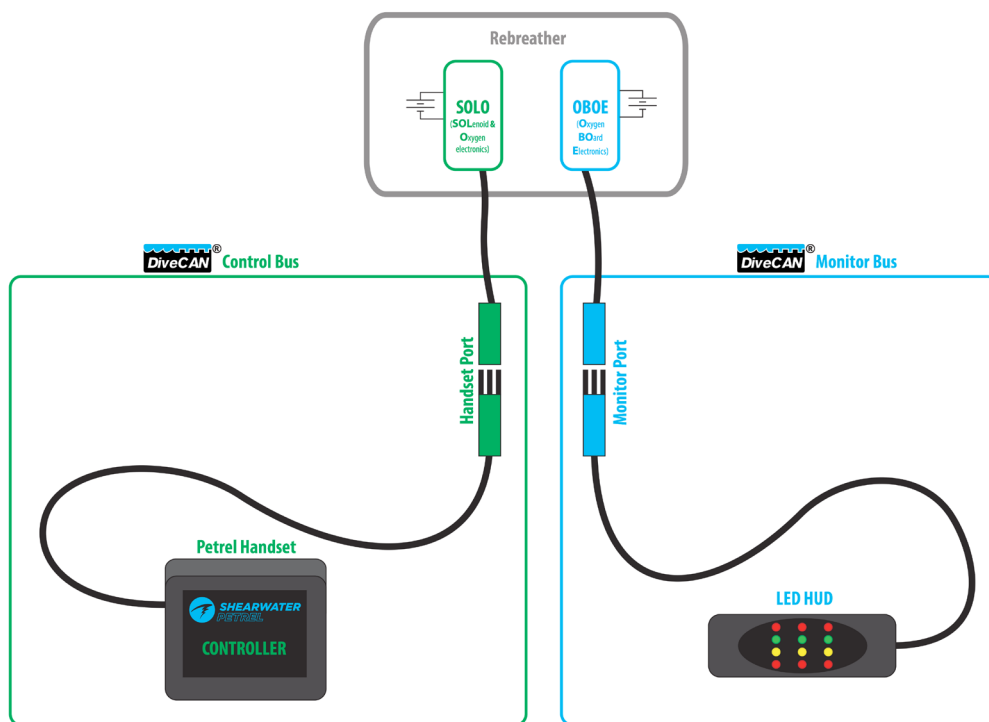

## 6.4 Turning on the controller

To turn the controller on, press both the MENU (left) and the SELECT (right) buttons at the same time. The JJ-CCR logo appears for a brief time, following by the controller’s main display.

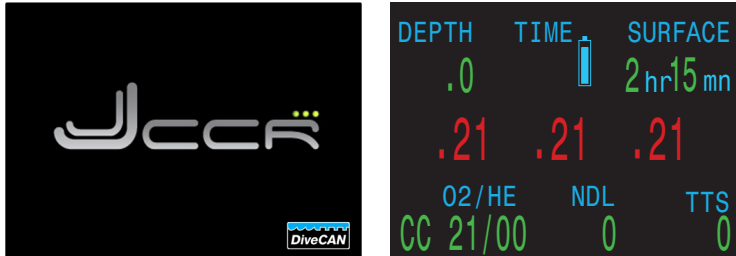

- Auto-On: The controller will automatically turn-on when submerged underwater. This is based on the presence of water. The controller buttons act as wet contacts.

## 6.5 Left and right buttons



As previously described, complete operation of the controller is implemented via the two titanium piezo-electric buttons.

When in a menu, button hints label each button. For example, the hints to the left tell us:

- Use MENU to change the brightness value
- Use SELECT to save the current value

Although both buttons also have special functions, it is possible to summarise the main function as follows:

### 6.5.1 Left (MENU)

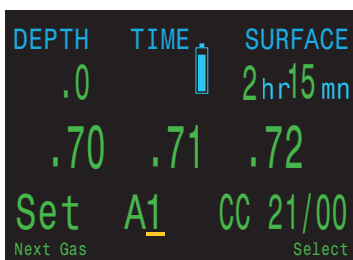

The left button (MENU) is used in order to scroll between the various controller menus. Or, if it is necessary to set a value, in order to increase this. In this way, one is able to press briefly on the left button in order to move from the "Switch Setpoint" menu to the "Select Gas" menu.

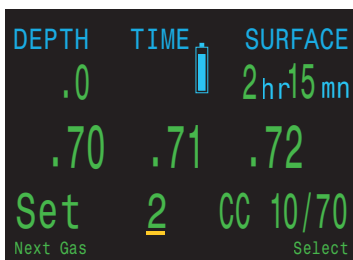
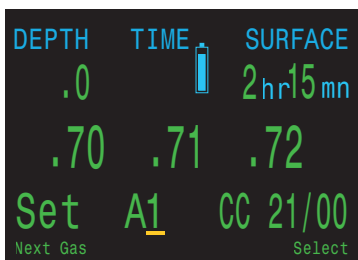

If one is in the "Select Gas" menu then pressing briefly on the left button will switch to the next gas.

## 6.5.2 Right (SELECT)

The right button (SELECT) is used in order to confirm the current selection. In some cases this can mean that an actual value is saved or a command is executed.



For example: If the user presses on the right button (SELECT) in the "Switch Setpoint" menu then the setpoint is changed to 1.3.

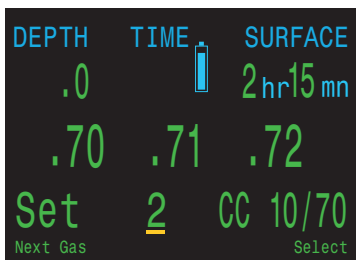

Or, if the user is in the "Select Gas" menu then pressing on the right button (SELECT) will select the displayed gas.

## 6.5.3 Overview of the button functions

The following table shows the various button functions:

Both buttons	
Press both buttons simultaneously	The controller is turning on
MENU (Left) button	
From main screen	Brings up menu
In a menu	Moves to the next menu item
Editing a setting	Changes setting value
SELECT (Right) button	
From main screen	Steps through info screens
In a menu	Performs command or starts editing
Editing a setting	Save the setting's value

## 6.6 The main display ●●●

The controller is equipped with a large display, which presents all of the requisite information for the diver in a clear and comprehensible format.

DEPTH TIME STOP TIME 60.6 22 40 1 1.23 1.25 1.27 O2/HE NDL TTS CC 18/45 0 46	Top Row Depth, Time & Deco Stops
	Centre Row PO2
	Bottom Row Mode, Gas & Deco Info

Color coding of text draws attention to problems or unsafe situations.

<b>WHITE</b>	White text indicates normal conditions.
<b>YELLOW</b>	Yellow is used for warnings that are not immediately dangerous but should be addressed. Sample Warning - a better gas is available <span style="background-color: yellow; padding: 2px;">O2/HE 15/40</span>
<b>FLASHING RED</b>	Flashing red is used for critical alerts that could be life threatening if not immediately addressed. <div style="display: flex; align-items: center; justify-content: center;"> <span style="background-color: black; color: red; padding: 2px;">GasPO2 .10</span> <span style="margin: 0 10px;">Flashes</span> <span style="background-color: black; color: red; padding: 2px;">GasPO2 .10</span> </div> Sample critical alert - continuing to breathe this gas could be fatal

Color blind users: The warning or critical alert states can be determined without the use of color.

Warning	Warnings display on a solid inverted background. Warning - doesn't flash. <span style="background-color: black; color: white; padding: 5px;">Warning</span>
Critical Alert	Critical alerts flash between inverted and normal text. <div style="display: flex; align-items: center; justify-content: center;"> <span style="background-color: black; color: white; padding: 5px;">Alert</span> <span style="margin: 0 10px;">Flashes</span> <span style="background-color: white; color: black; padding: 5px;">Alert</span> </div>

6.6.1 The Top Row ●●●

The top row shows depth and time information.



Depth:

Metric	In meters (displays with 1 decimal place up to 99.9m).
Imperial	In feet (no decimal places)



- If a red flashing "0" is displayed in place of the current depth then the pressure sensor is defective or requires a service.

Ascent Bar Graph:

Shows how fast you are currently ascending.

- Metric: 1 arrow per 3 meters per minute (mpm) of ascend rate
- Imperial: 1 arrow per 10 feet per minute (fpm) of ascend rate

Note: Deco calculations assume 10 mpm (33fpm) ascend rate

	Green when 1-3 arrows
	Yellow when 4-5 arrows
	Flashes red when 6 arrows or more

Dive Time:

The length of the current dive in minutes.

	The seconds display as a bar drawn below the word "Time." It takes 15 seconds to underline each character in the word. Does not display the seconds bar when not diving.
--	--

**Battery Icon:**

The default behavior is that battery icon is shown on the surface but disappears when diving. If low or critical then the battery icon will appear while diving.

	Battery is OK
	Battery needs to be changed
	Battery must be replaced immediately

**Stop Depth and Time:**

Stop Depth and Time	<p>Stop: The next stop in the current units (meters or feet. This is the shallowest depth to which you can ascend)</p> <p>Time: The time in minutes to hold the stop</p>
Decompression Stop violated	Will Flash Red if you ascend shallower than the current stop



By default the Petrel uses a 10 ft (3 m) last stop depth. At this setting, you may perform the last stop deeper if you choose. The only difference is that the predicted time-to-surface will be shorter than the actual TTS since off-gassing is occurring slower than expected.

There is also an option to set the last stop to 20 ft (6 m) if you wish.

**Surface Interval:**

When on the surface, the STOP DEPTH and TIME are replaced by a surface interval display. Shows the hours and minutes since the end of your last dive. Above 4 days, the surface interval is displayed in days.

The surface interval is reset when the decompression tissues are cleared.



**Deco Clear Counter:**

When deco clears the STOP DEPTH and TIME are replaced by a counter that begins counting up from 0.



### 6.6.2 The Center Row ●●●

The center row of the controller always displays the PO2 as measured by the three external O2 sensors. PO2 units are absolute atmospheres (1 ata = 1013 mbar).



PO2 **Flashes Red** when less than 0.40 or greater than 1.6. These limits can be adjusted in the Adv. Config 2 menu.



When a sensor is voted out, it displays in **Yellow**. Voting is performed to determine which sensors are most likely to be correct if the readings disagree. A sensor that is within 20% of either of the other sensors passes the voting and is included in the system average PO2 (used to control O2 injection and calculate decompression).



When the O2 sensors require calibration, the PO2 value will display as FAIL. Instructions can be found in the Calibration section.



#### Voting Failed:

If no consensus can be found between the three O2 sensors, then voting has failed. This displays as PO2 values alternating with "VOTING FAILED"



When voting fails, the solenoid will not inject O2 to maintain the PO2 setpoint. If this occurs, follow the training guidelines from your training agency.

When voting fails the decompression calculations use the PO2 from the lowest sensor (most conservative value), down to a minimum PO2 of 0.16.

### 6.6.3 The Bottom Row

The bottom row displays the current mode, gas and decompression information.



Circuit Mode:

The current breathing configuration. One of:

CC = Closed circuit.

BO = Open circuit bailout (bailout so displays in Yellow).



Current Gas (O2/He):

The current gas shown as a percentage of Oxygen and Helium. The remainder of the gas is assumed to be Nitrogen.

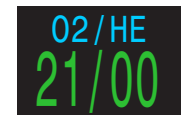

In closed circuit mode, this gas is the diluent. In open circuit mode this is the breathing gas.



Displays in Yellow when there is better deco gas available than the current gas.



No Decompression Limit (NDL):

The time remaining, in minutes, at the current depth until decompression stops will be necessary. Displays in Yellow when the NDL is less than the low NDL Limit (Default 5 minutes.)



Once NDL reaches 0 (i.e. deco stops needed), the NDL display is just wasting space. To address this, a few different values can be set to replace the NDL (see Dive Setup -> NDL Display).



The options are:

- Ceiling
- @+5
- Delta+5
- GF99
- SurGF

Each of these values is discussed further in the next section.



**Time-to-Surface (TTS):**

The time-to-surface in minutes. This is the current time to ascend to the surface including the ascent plus all required deco stops



All decompression information including Deco Stops, NDL, and Time to surface are predictions that assume:

- Ascent rate of 10mpm / 33fpm
- Decompression stops will be followed
- All programmed gases will be used as appropriate

The bottom row is also used to show additional information.

By using only the bottom row for this additional information, the critical information contained on the Top and Center Rows is always available during a dive.

The additional information that can be displayed on the bottom row includes:

Info Screens:	Shows additional dive information. Press SELECT (right button) to step through info screens.
Menus:	Allows changing settings. Press MENU (left button) to enter menus.
Warnings	Provide important alerts. Press SELECT (right button) to clear a warning.

**Sample Info Screen**

**Sample Menu**

**Sample Warning**

## 6.7 Info Screens ●●●

Info screens provide additional information that does not fit on the main screen.



Info screens display on the bottom row.

Press SELECT (right) button to step through the info screens.

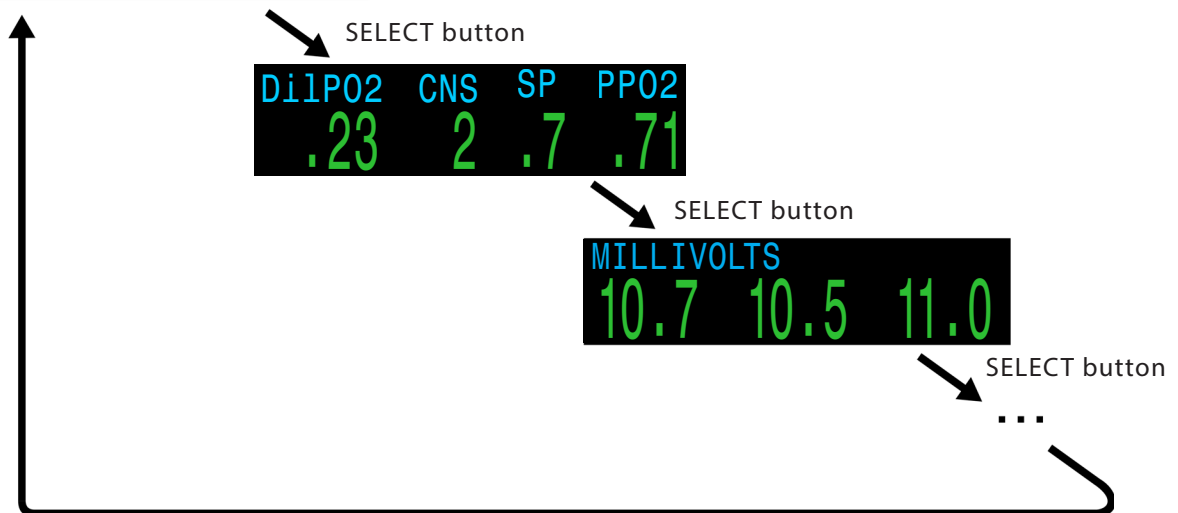

From the main screen, the SELECT (right) button steps through info screens.

When all info screens have been viewed, pressing SELECT again will return to the main screen.

Info screens also automatically time-out after 10 seconds, returning to the home screen. This prevents active gas information from being hidden for an extended period.

Note that the Compass, Tissues and AI Info screens do not automatically time out when active.

Pressing the MENU (left) button will return to the home screen at any time.

The next section gives descriptions of the data elements shown on the info screens.

**Last Dive Info Screen (surface only):**

The maximum depth and dive time from the last dive.



**Air integration:**

Only available if AI feature is turned on. The contents of the AI info line will automatically adapt to the current setup.



More information on AI features, limitations, and displays can be found in the Air Integration (AI) section.

**Compass:**

Marked headings appear in green while reciprocal headings are shown in red. Green arrows point in the direction of your mark when off course by 5° or more.

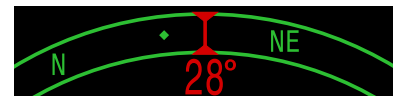

Compass info row will not time out and is only available when compass feature is turned on.

See the Compass section for more information.

**Millivolts:**

Shows the raw millivolt outputs of external PO2 cells. This is important information used to understand the O2 cell output behavior over time.



**Average Depth:**

Displays the average depth of the current dive, updated once per second. When not diving, shows the average depth of the last dive.



**Average Depth in Atmospheres (AvgATM):**

The average depth of the current dive, measured in absolute atmospheres (i.e. a value of 1.0 at sea level). When not diving, shows the average depth of the last dive.



**Maximum Depth:**

The maximum depth of the current dive. When not diving, displays the maximum depth of the last dive.



CNS Toxicity Percentage:  
Central Nervous System oxygen toxicity loading percentage.  
**Flashes Red** when 100 or greater.

The CNS percentage is calculated continuously, even when on the surface and turned off. When deco tissues are reset, the CNS will also be reset.

The CNS value (short for Central Nervous System Oxygen Toxicity) is a measure of your exposure to elevated partial pressures of oxygen (PO2) as a percentage of a maximum allowable exposure. As PO2 goes up, the maximum allowable exposure time goes down. The table we use is from the NOAA Diving Manual (Fourth Edition). The computer linearly interpolates between these points and extrapolates beyond them when necessary. Above a PO2 of 1.65 ata, the CNS rate increases at a fixed rate of 1% every 4 seconds.

During a dive the CNS never decreases. When back at the surface, a half-life of elimination of 90 minutes is used. So for example, if at the end of the dive the CNS was 80%, then 90 minutes later it will be 40%. In 90 more minutes it will be 20%, etc. Typically after about 6 half-life times (9 hours), everything is back close to equilibrium (0%).

Temperature:  
Reports the temperature in degrees Celsius or Fahrenheit.

Diluent PO2:  
The PO2 of the currently selected diluent. Not measured directly, but calculated as the fraction of O2 in the diluent multiplied by the current depth's pressure.  
Displays in **Flashing Red** when the PO2 of the diluent is less than 0.19 or greater than 1.65.  
When performing a manual diluent flush, you can check this value to see what the expected PO2 will be at the current depth. Also, can use to verify it is safe to flush with the diluent.

Setpoint (SP):  
The currently requested PO2 setpoint.

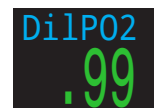

**Average PO2:**

The purpose of this value is to show what PO2 is actually being used for setpoint maintenance and decompression calculations.

The controller votes on the three measured PO2 values to decide what is the most likely true PO2. This value shows the result of the voting.

When you have bailed out to OC, the center row continues to display the external measured PO2. Use this info display to see the OC PO2.

In CC mode, displays in **Flashing Red** when less than 0.40 or greater than 1.6.

In OC mode, displays in **Flashing Red** when less than 0.19 or greater than 1.65.



**Fraction Inspired O2 (FiO2):**

The fraction of the breathing gas composed of O2. This value is independent of pressure.



**CEIL:**

The current decompression ceiling in the current units (feet or meters) not rounded to the next deeper stop increment. (i.e. not a multiple of 10ft or 3m). **Flashes Red** if you ascend shallower than the current ceiling.



**GF99:**

The current gradient factor as a percentage (i.e. super-saturation percent gradient)

0% means the leading tissue super-saturation is equal to ambient pressure. Displays "On Gas" when tissue tension is less than the inspired inert gas pressure.

100% means the leading tissue super-saturation is equal to the original M-Value limit in the Bühlmann ZHL-16C model.

GF99 is displayed in **Yellow** when the current gradient factor modified M-Value (GF High) is exceeded.

GF99 is displayed in **Red** when 100% (un-modified M-Value) is exceeded.



**SurfGF:**

The surfacing gradient factor expected if the diver instantaneously surfaced.



SurfGF colour is based on the current GF (GF99). If the current GF is greater than GF High, SurfGF will be displayed in Yellow. If the current gradient factor is greater than 100%, SurfGF will be displayed in Red.

**@+5/TTS:**

“At plus 5” is the TTS if remaining at the current depth for 5 more minutes. This can be used as a measure of how fast you are on-gassing or off-gassing.



Since this value is most useful when compared to the current TTS, the current TTS is displayed beside the @+5 value.

**DELTA +5:**

The predicted change in TTS if you were to stay at the current depth for 5 more minutes.

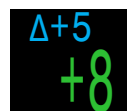

A positive “Delta plus 5” indicates that you are on-gassing the leading tissue while a negative number indicates that you are off-gassing the leading tissue.

**Dive End Time (DET):**

This is similar to TTS but is expressed as a time of day.



The time of day at which you can expect to surface if you depart immediately, ascend at 10mpm or 33fpm, change gases when prompted, and perform all decompression stops as directed.

**Gradient Factor:**

The deco conservatism value when the deco model is set to GF. The low and high gradient factors control the conservatism of the Bühlmann GF algorithm. See “Clearing up the Confusion About Deep Stops” by Erik Baker.



**VPM-B (and VPM-BG):**

The deco conservatism value when the deco model is set to VPM-B. For VPM-B, higher values are more conservative.



If the deco model is VPM-B/GFS, also displays the gradient factor for surfacing. For the gradient factor, higher values are less conservative.

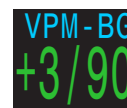

**Battery:**

The controller's internal battery voltage. Displays in **Yellow** when the battery is low and needs replacement. Displays in **Flashing Red** when the battery is critically low and must be replaced as soon as possible. Also shows battery type.



**External Battery (EXT V):**

The voltage of the external battery used to fire the solenoid.

**Flashing Red** when the battery is critically low and must be replaced as soon as possible.



Only sampled when solenoid is fired, so if solenoid has not yet fired, value is unknown and displays as a **Yellow** '?'.

**Pressure:**

The pressure in millibars. Two values are shown, the surface (surf) pressure and the current (now) pressure. The current pressure is only shown on the surface.



Note that typical pressure at sea level is 1013 millibar, although it may vary with the weather (barometric pressure). For example, surface pressure may be as low as 980 millibar in a low pressure system, or as high as 1040 millibar in a high pressure system.

For this reason, the PO2 displayed on the surface may not exactly match the FO2 (fraction of O2), although the displayed PO2 is still correct.

The surface pressure is set based on the lowest pressure the dive computer sees in the 10 minutes prior to the start of a dive. Therefore, altitude is automatically accounted for and no special altitude setting is required.

The surface pressure is set when the controller is turned on. If the Altitude setting is set to SeaLvl, then surface pressure is always 1013 millibars.

**Date and Time:**

In the format dd-mon-yy  
12 or 24 hour clock time.

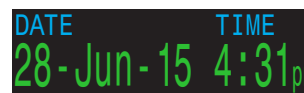
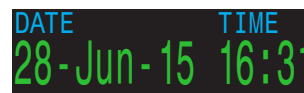

**Serial Number & Version:**

Each controller has a unique serial number.

The version number indicates the available features. The last two numbers are the firmware version (V92 in this image).

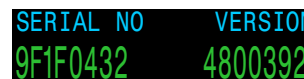

Tissues Bar Graph:

The tissues bar graph shows the tissue compartment inert gas tissue tensions based on the Bühlmann ZHL-16C model. Note that VPM-B also tracks tensions in the same way.



The fastest tissue compartment is shown on the top, and the slowest on the bottom. Each bar is the combined sum of the nitrogen and helium inert gas tensions. Pressure increases to the right.

The vertical black line shows the inert gas inspired pressure. The boundary between the green and yellow zones is the ambient pressure. The boundary between the yellow and red zone is the ZHL-16C M-Value pressure.

Note that the scale for each tissue compartment above the green zone is different. The reason the bars are scaled in this way is so that the tissues tensions can be visualized in terms of risk (i.e. how close they are as a percentage to Bühlmann's original super-saturation limits). Also, this scale changes with depth, since the M-Value line also changes with depth

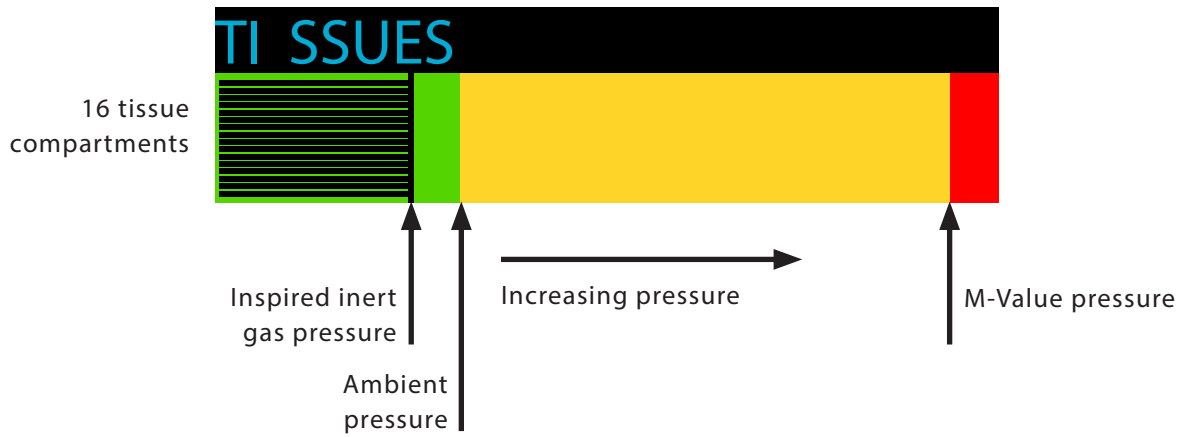

Sample Tissues Graphs

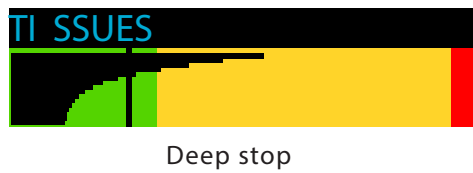
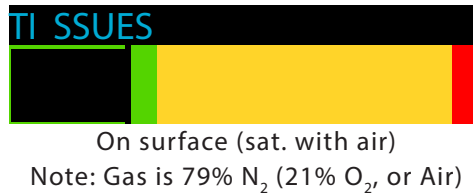

## 6.8 Notifications ●●●

This section describes the different types of notifications the controller may present the diver.

### Limitations Of Alarms

All alarm systems share common weaknesses.

They can alarm when no error condition exists (false positive). Or they can fail to alarm when a real error condition occurs (false negative).

Respond to alarms if you see them, but NEVER depend on them. Your judgment, education, and experience are your best defenses. Have a plan for failures, build experience slowly, and dive within your experience

### 6.8.1 Types of Notifications

There are two types of notifications displayed by this dive computer. Primary notifications and persistent notifications.

#### Primary Notifications:

Each primary notification displays as a message in yellow across the bottom row until dismissed.



The notification is dismissed by pressing either button.

For example, this "HIGH PO2" message will appear if the average PO2 goes above the high PO2 limit for more than 30 seconds.

The highest priority notification is listed first. If multiple errors occur simultaneously, the notification with the highest priority will be displayed. Clear the first notification by pressing a button to see the next one.

If vibration alerts are on, the unit will vibrate when the alert first occurs and every 10 seconds until it is acknowledged.

#### Persistent Notifications:

Persistent notifications complement primary notifications, displaying while a dangerous condition is present until the condition is resolved.

Persistent notifications cannot be cleared while the condition that caused them persists.

Example: when PO2 is in an unsafe range,

Center row text that shows a "Low PO2" or "High PO2" message. PO2 and gas values are highlighted and flash.

These persistent notifications will clear automatically once a safe PO2 is restored.



## 6.8.2 Vibration Alerts

In addition to visual notifications, the controller has vibration alerts to help quickly notify the diver of warnings, errors and dive events.

**Info: Vibration is Battery Dependant**  
Vibration Alerts are only available when using a 1.5 V Lithium or 3.7 V Rechargeable Li-ion battery.

If turned on, attention vibration alerts occur when a safety stop starts, pauses, or is completed. Vibration alerts also occur any time a primary notification is triggered and every 10 seconds until it is acknowledged.

There are some persistent conditions, such as low PO<sub>2</sub> that will cause vibration to continue until the condition is resolved.

The vibration alert can be toggled on or off in System Setup > Alerts Setup , or in the Dive Setup menu.

A Test Vibration tool is also available in the Dive Setup menu and should be used regularly before diving to ensure the vibrator is functioning properly.

**Caution**  
Although vibration alerts are very useful, never rely on them for your safety. Electromechanical devices can and will eventually fail.  
  
Always be proactively aware of your depth, no-decompression limit, gas supply, and other critical dive data. You are ultimately responsible for your own safety.

## 6.8.3 List of primary notifications

The following table lists primary notifications you may see, their meaning, and steps to take to solve any problems.

If multiple warnings are triggered simultaneously, the notification with the highest priority will be displayed. Clear that notification by pressing any button to see the next notification.

**Contact Shearwater:**  
The subsequent list of notifications is not exhaustive. Please contact Shearwater if you experience any unexpected errors: [info@shearwater.com](mailto:info@shearwater.com)

Display:	Meaning	Action to take
	The PO2 is below the limit set in the PO2 limits menu	Change your breathing gas to one safe for the current depth.
	The PO2 is above the limit set in the PO2 limits menu.	Change your breathing gas to one safe for the current depth.
	A required decompression stop was violated.	Descend deeper than the currently displayed stop depth. Monitor for symptoms of DCS. Use extra conservatism for future repetitive dives.
	The ascent was sustained as faster than 10m/min (33ft/min)	Use a slow ascent rate. Monitor for symptoms of DCS. Use extra conservatism for future repetitive dives.
	The internal battery is low.	Replace the battery.
	The decompression tissue inert gas loading has been set to default levels.	Plan repetitive dives accordingly.
	Central Nervous System (CNS) toxicity clock exceeded 150%.	Switch to a gas with a lower PO2 or ascend shallower (decompression ceiling allowing)
	Central Nervous System (CNS) toxicity clock exceeded 90%.	Switch to a gas with a lower PO2 or ascend shallower (decompression ceiling allowing)
	NDL is less than low NDL alert value. (Only if alert active)	Ascend soon to avoid decompression obligation.
	Depth is deeper than depth alert value. (Only if alert active)	Ascend above depth limit.
	Dive time has surpassed time alert value. (Only if alert active)	End dive safely.
	No communications for 30 to 90 seconds.	See the Transmitter Connection Issues section for more information.
	No communications for 90+ seconds	See the Transmitter Connection Issues section for more information.



Display:	Meaning	Action to take
	Low transmitter battery.	Replace the transmitter battery.
	Cylinder pressure exceeds rated pressure by more than 10%.	Properly set the rated pressure in the AI Setup menu.
	Cylinder pressure has fallen below the critical pressure.	Be aware that gas is running low. Begin to end your dive and perform a controlled ascent to the surface.
	The computer has reset to recover from an unexpected software condition.	If this occurs more than once over a long period, please report to Shearwater Research Inc.
	This reset shows up after a software update. This is the normal event that shows the computer has been rebooted after the software update.	N/A
	Firmware update failed, possibly due to a communications error or corrupted file.	Try the firmware upgrade again. Contact Shearwater if problem persists.

## 6.9 Compass

The controller has a build in tilt compensated compass.

Viewing the Compass:

When enabled, the compass is viewed by pressing the SELECT (right) button once. Press SELECT again to continue on to view the regular info screens.

Unlike the regular info screens, the compass never times out back to the main screen. Pressing the MENU (left) button brings up the Mark Heading option. Pressing MENU again returns to the main screen.

Compass features:

- 1° resolution
- $\pm 5^\circ$  accuracy
- Smooth, high-speed refresh rate
- User set heading marker with reciprocal
- True North (declination) adjustment
- Tilt compensation  $\pm 45^\circ$



### Compass Limitations:

**Calibration** - The digital compass needs occasional calibration. This can be done in the System Setup -> Compass menu.

**Battery Changes** - When the battery is changed, the compass requires calibration.

**Interference** - Since a compass operates by reading the Earth's magnetic field, the compass heading is affected by anything that distorts that field or creates its own. Steel objects and electric motors or cabling (e.g. from dive lights) should be kept at a distance. Being close to or inside a shipwreck may also affect the compass.

**Magnetic declination** (also called magnetic variation) is the difference between magnetic and True North. This can be compensated in the Compass Setup menu using the True North setting. The magnetic declination varies around the world, so will need to be readjusted when traveling. **Magnetic inclination** (or magnetic dip) is how much the Earth's magnetic field points up or down. The compass automatically compensates for this angle. However, near the poles, the inclination angle can exceed  $80^\circ$  (i.e. the magnetic field points almost directly up or down), in which case the specified accuracy may not be met.

### 6.9.1 Mark Heading (Compass)

Marking a Heading:

To mark a heading, when viewing the compass press the MENU (left) button. This brings up the "Exit Mark" menu. Press the SELECT (right) button to mark the heading.



The marked heading is shown with a green arrow. When within  $\pm 5^\circ$  of the heading, the degrees display turns green.



The reciprocal heading ( $180^\circ$  from marked heading) is shown with a red arrow. When within  $\pm 5^\circ$  of the reciprocal heading, the degrees display turns red.



When more than  $5^\circ$  off the marked heading, a green arrow shows the direction back to the marked heading. Also, the offset degrees to the heading are displayed ( $16^\circ$  in the example image). This offset is useful when navigating patterns. For example, a box pattern requires turns at  $90^\circ$  intervals, while a triangle pattern requires  $120^\circ$  turns.



### 6.10 Air Integration

The controller is equipped with 4-transmitter air integration capability.

Please refer to the Shearwater SWIFT manual for further information about the "Air Integration" features and functions.

**NOT SUPPORTED:**

The AI function is currently not supported by JJ-CCR ApS. The JJ-CCR rebreather is fully certified to a depth of 100 meters. Whereas the controller's air integration system is under EN 250 certified for use with air only to a maximum depth of 50 meters. Furthermore, the two pressure gauges are part of the rebreather's CE certification and a removal voids the CE.

## 6.11 Menus



Press MENU (left) button to step through the menus.

Press SELECT (right) button to execute command or enter sub-menu.

Menus display on the bottom row.

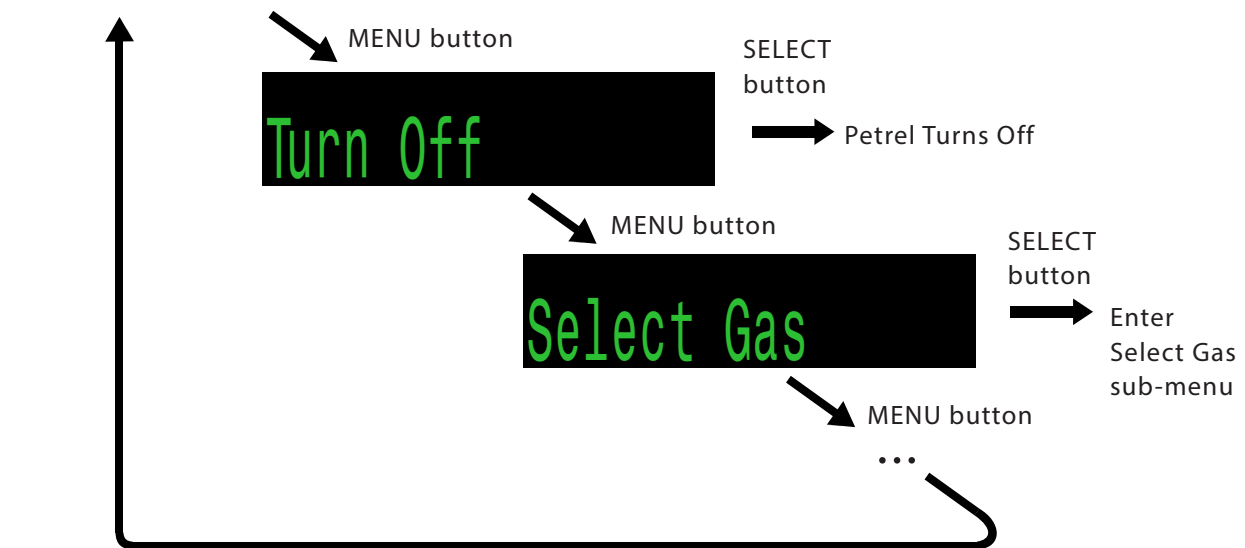

The controller is equipped with adaptive menu guidance. This means that unnecessary menus are automatically hidden in the respective mode. The controller also distinguishes between the display of the menu item in diving mode or above water. As such, the two menu items "Turn Off" and "Calibrate" are unavailable when in diving mode.

Menus perform actions and allow settings to be changed.

Starting from the main screen, pressing the MENU (left) button steps through the menus. When all menus have been viewed, pressing MENU again will return to the main screen.

Pressing the SELECT (right) button when a menu is displayed, either performs that action or enters a sub-menu.

If no buttons are pushed for 1 minute, the menu system will time-out, returning to the main screen. Anything that had been previously saved will be retained. Anything that was in the middle of editing will be discarded.

## 6.12 Menu structure



### 6.13 Menu reference ●●●

In this chapter all controller menu items are listed individually and explained.

### 6.14 Turn Off ●●●

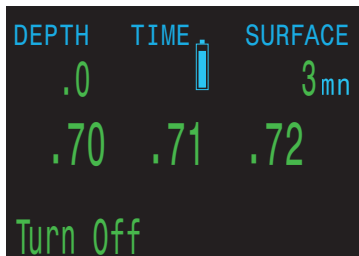

The "Turn Off" item puts the controller to sleep. While sleeping, the screen is blank, but the tissue contents are maintained for repetitive diving. The "Turn Off" menu item will not appear during a dive. It will also not appear after a dive until the End Dive Delay time has expired to allow for a continuation dive.

- In dive mode this menu item is NOT displayed!
- During the first 2 minutes after diving, the controller maintains surface interval and it cannot be turned off at this time.

### 6.15 Calibrate (calibration of the O2 sensors) ●●●

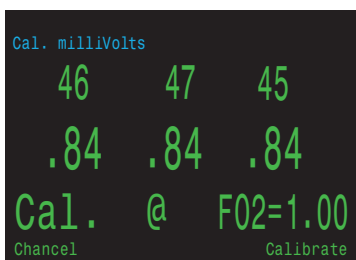

The O2 sensors are calibrated with oxygen via this menu item. The controller for the JJ-CCR Rebreather has a calibration sequence that runs automatically.

- In order to calibrate and dive at altitude it is necessary to set the "Altitude" option to "Auto" in the "Display setup" menu. Only then is the current ambient pressure taken into account in the calibration.
- When surface pressure is less than 960 millibar, the controller forces the use of auto altitude setting (i.e. cannot use the SeaLvl setting).
- PO2 calibration cannot be performed when pressure is above 1080 mbar.
- PO2 values below 0.4 flash in red. If the sensor millivolts are outside an acceptable range then they are shown in yellow. Good sensors should be in the range of 35 - 65 mV at sea level in 100% oxygen. A sensor will fail calibration if not in the range of 30mV to 70 mV. This allowable range scales automatically with changes to FO2 and barometric pressure. If outside the allowable range, a millivolt reading is shown in yellow.
- Important: The calibration gas must be set to 100% oxygen (see system setup – option "Calibrate O2")
- In countries in which 100% oxygen is not available it is naturally necessary to use the respective oxygen content.

- The controller does not stipulate the individual steps during calibration! It is therefore very important to precisely adhere to the sequence.

1. Open the oxygen valve and check the current pressure in the oxygen cylinder.
2. Open the mouthpiece (= CC mode).
3. Select the menu item "Calibrate". Check that the calibration gas displayed is 100% oxygen (=CAL @ FO2 = 100).
4. Pressing the right button (YES) results in the calibration process starting.
5. The solenoid now allows oxygen to flow into the circuit until the sensor millivolts stabilise and no longer change. This may take some time. Please be patient. During calibration, the PO2 and mV for every O2 sensor is displayed and the countdown bar at the bottom of the display goes down.
6. Calibration has been successfully completed as soon as the controller shows the "O2 Cal. Report" on the display. With the status "SUCCESS" for a successfully calibration or "FAILED" when the calibration was not successfully.
7. After confirming the "O2 Cal. Report" it switches back to the main display.

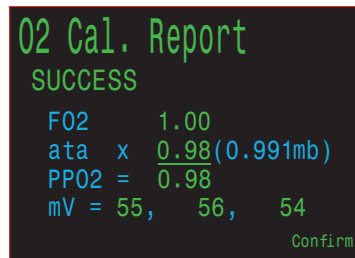
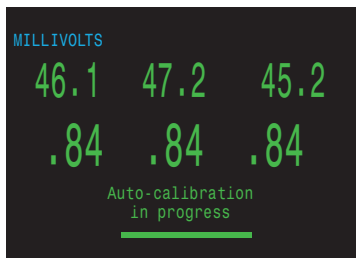

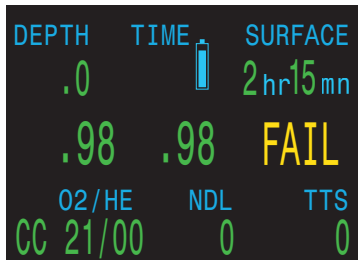

#### One sensor displays FAIL after calibration

This could indicate a bad sensor. It has failed because the mV output was not in range (30-70 mV). The sensor could be old or damaged, and should be inspected. Damage and corrosion to wires or connectors is also a common problem. Fix the problem and recalibrate before diving.

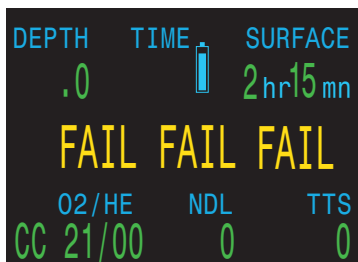

#### All sensors display FAIL after calibration

This could be caused by an accidentally unplugged cable or a damaged cable or connector. Also, accidentally performing the calibration in air or without a proper oxygen flush could cause this problem. A failed calibration can only be fixed by performing a successful calibration..



#### PO2 does not show 0.98 after calibration

If the Altitude setting in the Display Setup menu is set to Auto, then the PO2 after calibration may not be exactly equal to the FO2.

This is because weather causes minor changes in barometric pressure. For example, say a low-pressure weather system has reduced the normal (1013mbar) barometric pressure to 990mbar. The PO2 in absolute atmospheres is then  $0.98 * (990/1013) = 0.96$ .



The 0.96 PO2 result is, in this case, correct. At high altitudes, the difference between FO2 and PO2 will be even larger. To see the current pressure, start at the main screen and press the SELECT button a few times (displays as Pressure mbar NOW).

If you are at sea level, and want the calibrated PO2 to exactly match the FO2, then change the Altitude setting to SeaLvl. Only do this when actually at sea level, and also be aware that using this SeaLvl setting is actually introducing error into the PO2 measurements.

- In dive mode the menu item "Calibrate" is NOT displayed!
- The oxygen sensors should be calibrated regularly. This should ideally take place prior to every dive and at least once daily with multiple dives.

### 6.15.1 External PO2 monitoring

This system is connected to three sensors inside the rebreather. The PO2 input from these sensors is used to determine the system average PO2 which is used to govern solenoid injections and for decompression calculations and CNS tracking.

A voting algorithm is used to decide which of the three sensors are likely to be correct. If a sensor matches either of the other two sensors within ±20%, it passes voting. The system average PO2 is the average of all sensors that have passed voting.

For instance, in the example above, sensor 1 has failed voting. The PO2 is displayed in yellow to show that it has failed voting. The system average PO2 is the average PO2 of sensor 2 and 3.

If all sensors fail voting, then the display will alternate VOTING FAILED with the PO2 measurements (which will all be yellow to indicate that voting has failed). When voting has failed, while still in closed circuit mode, the lowest PO2 reading will be used for deco calculations (i.e. the most conservative value).

PO2 values below 0.4 or above 1.6 flash in red.

DEPTH	TIME	STOP	TIME
24.7	10	24	1
1.31	1.29	1.25	
O2/HE	NDL	TTS	
CC 21/00	0	28	

DEPTH	TIME	STOP	TIME
24.7	10	24	1
1.66	1.67	1.65	
O2/HE	NDL	TTS	
CC 21/00	0	28	

If the controller is switched to BO it uses the PO2 of the active gas at the momentary depth in order to calculate the decompression.

### 6.15.2 Checking calibration during a dive

DEPTH	TIME	STOP	TIME
.0			
.21	.21	.21	
DilPO2	CNS	SP	AvgPO2
.17	0	.7	.21

It is a wise precautionary measure to check the correct functionality of the oxygen sensors from time to time during a dive. It is first necessary to flush the diluent from the circuit (= diluent flush). Then press the right button once in order to display the PO2 of the diluent at the current depth. If the circuit has been correctly and fully flushed with the diluent then the oxygen sensors must display the same PO2 value. If this is not the case then the diver should immediately bailout.

Another test through which to ascertain whether the oxygen sensors are functioning correctly is to flush the circuit at 6 metres with oxygen (= oxygen flush). The PO2 should lie above 1.5 after this. If this is not the case, the oxygen sensors should be replaced.



### 6.16 End Dive ●●●



Within the "Advanced Config" menu you can specify for how long the controller will stay in the dive mode after surfacing. Another descend during this time will count as one dive in the internal dive log. With the option "End Dive" the diver can end the current dive and another descend will be added as a second dive in the internal logbook.

- The option "End Dive" is only available when the controller is still in dive mode and when the diver is on the surface.

### 6.17 Switch Setpoint ●●●

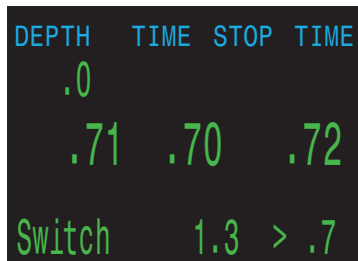
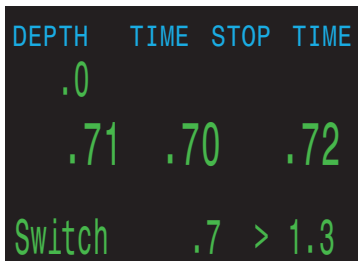

Pressing SELECT when this menu is displayed changes the PO2 setpoint from the low setpoint to the high setpoint or vice-versa. To redefine the PO2 value of a setpoint, use the Dive Setup menu.

This menu item performs a manual switching of PO2 setpoint. Automatic setpoint switching can be setup in the System Setup > Auto SP Switch menu. When auto setpoint switches are enabled, this menu item is still available to provide manual control.

- During a dive the "Switch Setpoint" menu item will be the first item displayed, since the "Turn Off" and "Calibrate" displays are disabled when diving.

## 6.18 Select Gas

```

DEPTH  TIME  STOP  TIME
  .0
  .71  .70   .72
Select Gas
  
```

```

DEPTH  TIME  STOP  TIME
  .0
  .71  .70   .72
 1 OC   On   50/00
Next           Select
  
```

This menu item allows you to pick a gas from the gases you have created. The selected gas will be used either as the breathing gas in open circuit mode, or the diluent in closed circuit mode.

- The selectable gases are sorted from highest to lowest oxygen content! If two gases have the same oxygen content then the gas with the lower helium content is brought to the front of the sequence.
- With a gas change the diver receives no gas recommendation. The diver must personally select the desired gas from the list of available gases.
- If an alternative gas to the set gas is available then the active gas starts to flash yellow in the main menu. The display thereby indicates switching to the other gas or removing it from the list of gases if it is not to be used.

```

DEPTH  TIME  STOP  TIME
  .0
  .71  .70   .72
A2 OC   On   50/00
Next           Select
  
```

If "Select Gas" is displayed then it is necessary to press the right "Select" button, in order that the first available gas is displayed. Pressing the left "Next Gas" button multiple times results in all available gases being displayed, one after the other. Once all available gases have been displayed the "Select Gas" menu appears once again without the current selection having actually changed. The current active gas is displayed with an "A" before the number.

Once the desired gas is displayed it can be selected by pressing the right button (Select). The controller switches automatically to the main display and the current gas is now shown in the footer. The JJ-CCR controller enables the definition of 5 different gases in closed circuit (CC) and open circuit (BO) bailout mode respectively. The gases can be entirely different and only those gases applicable to the actual active mode are displayed. This means that only the maximum 5 gases for open circuit bailout are displayed when in BO mode, and likewise only the maximum 5 gases for CC mode are displayed when in CC mode. The separation of the two gas lists enables a simple open circuit (BO) bailout: The diver dives with the JJ-CCR Rebreather and has various stages throughout, at which he can switch to this in the event of a rebreather failure. In CC mode he defines his diluent and in open circuit (BO) bailout mode he defines all gases that he has as additional stages. If, during the dive, there is a problem with the rebreather and the diver is required to switch to stages, he simply switches the controller from closed circuit (CC) mode to open circuit (BO) bailout mode. Because all gases are already defined, the decompression and TTS are appropriately adjusted and he is able to continue diving safely without needing to make any further setting adjustments on the controller.

### 6.18.1 Classic Style Select Gas



Two styles of Select Gas menus are available, Classic and New.

Change between the two styles in the Adv. Config 1 menu.

The classic Select Gas style is as described on the previous page.

- One gas is shown at a time.
- Press MENU to step through gases, and SELECT to select the shown gas.
- Gases are sorted from highest O2% to lowest O2%.
- Stepping past the last gas will exit the menu without changing the active gas.
- Upon entering the Select Gas menu, the first gas shown is always the highest O2% gas.

### 6.18.2 New Style Select Gas

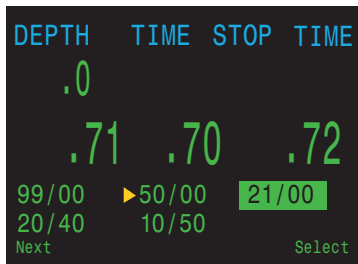

The new style makes visualizing the gas list easier. It also reduces button presses for deco gas switches.

Change between the two styles in the Adv. Config 1 menu.

- Shows all gases on the screen at once.
- Press MENU to step through gases, and SELECT to select the pointed to gas.
- A gas must be selected to exit the menu (scrolling past last gas wraps back to first gas).
- The active gas is shown with a green background.
- Turned off gases are shown in magenta (purple).
- Gases are sorted from highest O2% to lowest O2%.
- When diving and there is a deco stop, the first gas pointed to will be the most appropriate gas (highest PO2 less than 1.61). This reduces button presses in most cases.
- On the surface or when no deco stops are needed, the first gas pointed to will be the active gas.

### 6.19 Switch CC/BO (Between Closed and Open Circuit Bailout Mode) ●●●

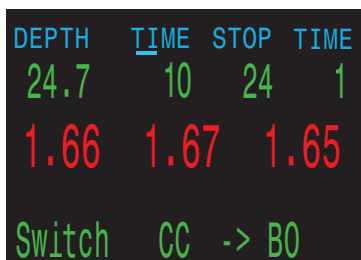

Depending on the current controller setting, this selection will show as either "Switch CC > BO" or "Switch BO > CC".

Pressing SELECT will select the displayed mode for decompression calculations. When switching to Bailout while diving, the most appropriate open circuit gas will become the breathing gas for calculations. At this point, the diver may want to switch to a different gas, but since the diver may have other things to deal with, the controller will make a "best guess" of which gas the diver would choose.

- When changing to open circuit (BO) bailout mode the controller automatically switches to low setpoint. The display for the bailout mode (BO) is shown in yellow because the controller should usually be in CC mode.
- If the diver switches to open circuit (BO) bailout mode then the gas best suited at that time to being used as a breathing gas is selected and applied for the decompression calculations. The diver is subsequently able to change to an alternative gas at any time, if he does not concur with the selection. To do so he must choose the "Select Gas" menu function.
- External PO2 sensors readings will continue to be displayed so the user can monitor their loop PO2 in case they need to return to the loop.

## 6.20 Dive Setup ●●●

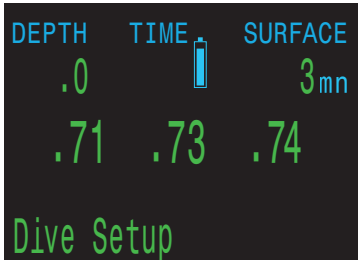

All of the Dive Setup menus are available both on the surface and when diving.

The values in Dive Setup can also be accessed in the Systems Setup menu, but the System Setup menu is not available when diving.

Pressing the right (SELECT) button will enter the Dive Setup sub-menu.

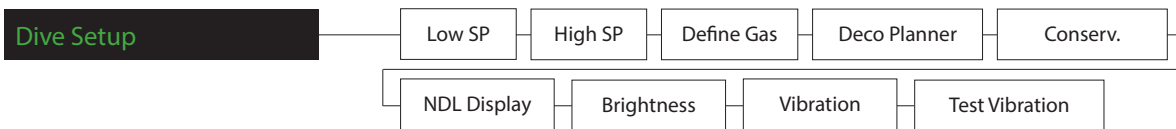

### 6.20.1 Edit Low SP (Low Setpoint) ●●●

This item allows you to edit the low setpoint value. Initially it will display the currently selected value.



Press the right (Edit) button to open the edit display. Press the left (Change) button to increment the setpoint.



Values from 0.4 to 1.5 are allowed. Incrementing past 1.5 returns the value to 0.4. Press the right (Save) button to lock in new low setpoint.

### 6.20.2 Edit High SP (High Setpoint) ●●●

Works in exactly the same way as the Edit Low Setpoint function above.



### 6.20.3 Define Gas

The define gas function allows you to set up 5 gases in Closed Circuit and 5 gases in Open Circuit. You must be in Bail Out mode to edit open circuit gases, and you must be in Closed Circuit to edit closed circuit diluents. For each gas, you can select the percentage of oxygen and helium in the gas. The remainder is assumed to be nitrogen.

Pushing the right (Define) button presents the function to define gas number 1.

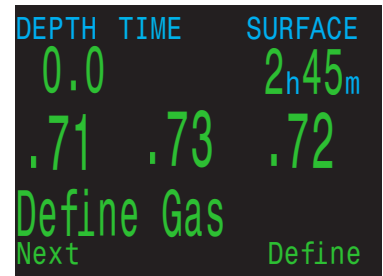

The left (Next) button increments to the next gas.

Press the right (Edit) button to edit a gas.



The first option is to toggle the gas on or off as indicated by the underline. Use the left (Change) button to toggle the gas on.

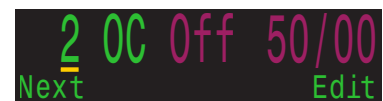

Continuing along, the gas contents are edited one digit at a time. The underline shows the digit being edited.



Each push of the left (Change) button increments the digit being edited. When the digit reaches 9, it will roll over to 0.



Pushing the right button (Next) will lock in the current digit, and move on to the next digit.

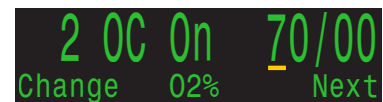

A helpful indicator of what is being edited is included in the center at the bottom.

Pushing the right (Save) button on the last digit will finish editing that gas, and bring you back to the gas number. You can continue to increment through the gases pressing the left (Next) button.



The "A" denotes the active gas. You cannot turn off the active gas in the Define Gas menu. If you try, it will generate an error. You can edit it, but cannot set both the O2 and HE to 00.



Setting any gas to 00/00 will automatically turn it off.

The computer will display all 5 gas entries available to allow you to enter new gases.



Pressing MENU one more time when the fifth gas is displayed will return you to the "Define Gas" menu item.



### 6.20.4 Define Gas (New Style)

Similar to the New Style Select Gas menu, the New Style Define Gas menu shows all gases on the screen at once at the expense of font size.

If the Gas Select style is set to New, the controller will also display the New Style Define Gas Menu.

When the Define Gas menu is opened, all of the gases will be displayed. Turned on gases will be in green, turned off gases will be magenta, and the currently active gas will be highlighted.

Press the left (Next) button until the arrow points to the gas you would like to edit, then press the right (Edit) button.

Similar to the Classic Style Define Gas menu, the attribute being toggled is displayed at the bottom of the display.

Gases can be toggled on or off, and the gas fractions of oxygen and helium can be changed one digit at a time.

When you are finished editing move the arrow to the Exit option and press the right (Exit) button to leave the define gas menu.

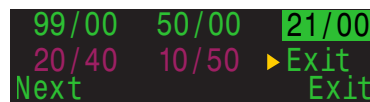
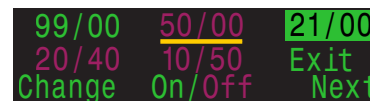
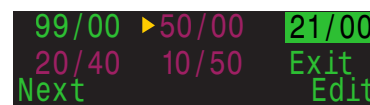
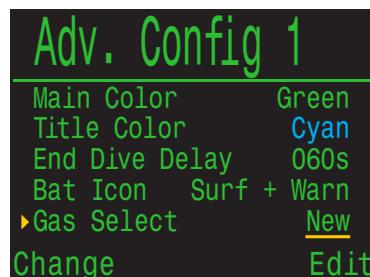

Turn off gases you are not carrying:

Only turn on the gases you are actually carrying and plan to use on the dive. Failure to abide by this warning may result in inaccurate decompression information being displayed.

With radio station gases, the computer has a full picture of the OC and CC gases you are carrying and can make informed predictions about decompression times. There is no need to turn gases off and on when you switch from CC to OC, because the computer already knows what the gas sets are. You should only have the CC and OC gases you are actually carrying turned on.

If you often use other gases, you can enter the gas and turn it off. You can turn gases on and off during a dive and you can also add or remove a gas during the dive if needed.



## 6.20.5 Deco Planner

### Introduction:

- Calculates decompression profiles for simple dives.
- Calculates gas consumption based on RMV.
- Can be used both on the surface and during a dive.



### Setup:

- The planner uses the current gases programmed in the current dive mode, as well as the current conservatism (GF low/high) settings. VPM-B dive planning is available on units with the optional VPM-B unlock.

### Deco Planner Limitations:

- The controllers Deco Planner is intended for simple dives.
- Multi-level dives are not supported.
- The Deco Planner does not provide thorough validation of the profile. For example, it does not check for nitrogen narcosis limitations, gas usage limitations, or CNS percentage violations.
- The user is responsible for ensuring a safe profile is followed.

### IMPORTANT:

The controllers Deco Planner makes the following assumptions:

- Descent rate is 18 m/min (60 ft/min) and the ascent rate is 10 m/min (33 ft/min).
- The gas in use at any time will be the gas with the highest PO<sub>2</sub> within the PO<sub>2</sub> limits.
- The planner will use the configured last stop depth.
- The RMV is the same during the bottom phase of the dive as it is while traveling and during deco

When used at the Surface:

Enter the dive bottom depth, bottom time, respiratory minute volume (RMV) and PO2.

Note: Residual tissue loading (and CNS%) from recent dives will be used in calculating the profile

When the correct values are entered, confirm decompression settings and starting CNS, then select "Plan".

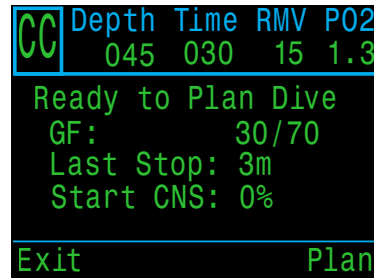
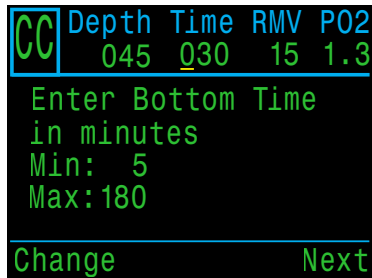

When used during a dive:

Computes the decompression profile assuming the ascent will begin immediately. There are no settings to enter. (RMV is last used value).

Result Screens:

The results are given in tables showing:

Display	Description
Stp	Stop Depth in meters or feet
Tme	Stop Time in minutes
Run	Run Time in minutes
Gas	Indicates the breathable gas. The Dive Planner takes into account all gases entered!
Qty	Indicates the gas quantity in litres or cuft. This info is only displayed in the OC or BO plan. The CC plan does not display this information!
Bot	Bottom Time
Asc	Ascent Time

The first few rows will show the bottom time (bot) and the ascent time (asc) to the first stop. Multiple initial ascent legs may be shown if gas switches are needed.

If there are too many stops to display, the results will be split onto several screens.

A bailout plan based on the programmed bailout gases will automatically be generated after the closed circuit deco summary.

CC	Depth	Time	RMV	P02
	045	030	15	1.3
Stp	Tme	Run	Gas	
45	bot	30	10/50	
21	asc	33	10/50	
21	1	34	10/50	
18	2	36	10/50	
15	2	38	10/50	
Quit				Next

BO	Depth	Time	RMV	P02
	045	030	15	1.3
Stp	Tme	Run	Gas	Qty
6	6	53	99/00	242
3	11	64	99/00	212
Quit				Next

After the last page of the deco schedule, bailout gas usage and deco summary screens show the expected quantity of each gas used for the dive, the total dive time, the time spent on deco and final CNS%.

BO	Depth	Time	RMV	P02
	045	030	15	1.3
Gas Usage, in Liters				
	99/00:	453		
	50/00:	410		
	21/25:	260		
Quit				Next

CC	Depth	Time	RMV	P02
	040	020	15	1.3
CC Summary				
	Run:	65 minutes		
	Deco:	35 minutes		
	CNS:	36 %		
Quit				Next

If no decompression is required, no table will be shown. Instead, the total No-Decompression-Limit (NDL) time in minutes, at the given bottom depth will be reported. Also, the gas quantity required to surface (bailout in CC) will be reported.

CC	Depth	Time	RMV	P02
	024	030	14	1.3
No Deco Stops.				
Total NDL at 24m is 30 minutes				
Bailout gas quantity is 73 Liters.				
Quit				Done



### 6.20.6 Conserv.

The conservatism settings (GF High and GF Low) can be edited in the Dive Setup menu.

While diving, only the GF High value can be edited. This allows changing the surfacing conservatism during a dive. For example, if you worked much harder on the bottom segment than expected, you may wish to add conservatism by reducing the GF High setting.

### 6.20.7 NDL Display (GF99, CEIL, NDL, @+5 or Δ+5 display)

While in decompression, NDL is 0. This makes the NDL area wasted space until decompression is cleared.

The NDL Display option allows you to replace the NDL with different information once decompression is required and the NDL has gone to 0.

The NDL display option can be changed during the dive through the dive setup menu.

Option	Description
NDL	NDL (No Decompression Limit). The NDL will always be displayed during the dive.
CEIL	Shows the current decompression ceiling not rounded to the next deeper stop increment. (i.e. not a multiple of 3m or 10ft.)
GF99	Shows the current gradient factor as a percentage (i.e. super-saturation percent gradient).  0% means the leading tissue super saturation is equal to ambient pressure. Displays "On Gas" when tissue tension is less than inspired inert gas pressure.  100% means the leading tissue super saturation is equal to the original M-Value limit in the Bühlmann ZHL-16C model.  GF99 is displayed in <b>Yellow</b> when the current gradient factor modified M-Value (GF High) is exceeded. GF 99 is displayed in <b>Red</b> when 100% (un-modified M-Value) is exceeded.
SurfGF	Shows the surfacing gradient factor expected if the diver instantaneously surfaced.  The SurfGF colour is based on the current GF (GF99). If the current GF is greater than GF High, SurfGF will be displayed in <b>Yellow</b> . If the current gradient factor is greater than 100%, SurfGF will be displayed in <b>Red</b> .
+@5	Shows the TTS if remaining at the current depth for 5 more minutes. This can be used as a measure of how fast you are on-gassing or off-gassing.
Δ+5	Shows the predicted change in TTS if you were stay at the current depth for 5 more minutes.  A positive "Delta plus 5" indicates that you are on-gassing the leading tissue while a negative number indicates that you are off-gassing the leading tissue.
MINI	Shows on the right side of the bottom row two additional pieces of custom information. It can be configured from the "Setup Setup > Deco"

## 6.20.8 Brightness ● ● ●

The display brightness has four fixed brightness settings plus an Auto mode.

Mode	Description
Auto	The light sensor measures the ambient light and automatically adjusts the brightness of the display.
Low	Permanent minimum brightness - Second longest battery life.
Med	Permanent medium brightness - Best mix of battery life and readability.
High	Permanent maximum brightness - Easiest readability, especially in bright sunlight.
Cave	Suitable for very dark environments like caves - Longest battery life.

- The “Auto” setting works well in most situations.
- The brightness of the display is the major determinant of battery life. Up to 80% of the power consumption is to power the display. When a low battery alert occurs, the display brightness is automatically reduced to extend battery life.

## 6.20.9 Vibration On/Off ● ● ●

Shows current state of vibration function. Press the right (Edit) button to toggle the vibration function on or off.



## 6.20.10 Test Vibration ● ● ●

Press the right (Ok) button to quickly test the vibration function to ensure it's working correctly.



Regularly test vibration alerts with the Test Vibration tool to ensure they are working and you can hear/feel them through your exposure suit.

## 6.21 Dive Log

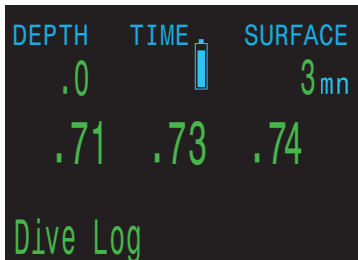

Using this menu item it is possible to access a range of submenus for the controller's dive logbook. Up to 1000 hours of detailed logs can be stored at the default sampling rate of 10 seconds.

The Dive Log menu is only available when on the surface.



### 6.21.1 Display Log / Edit Log

Use this menu to display a list of logged dives and view details. Select a dive to view from the Dive log list.

The profile of the dive is plotted in blue, with decompression stops plotted in red. The following information is displayed by scrolling through the dive log screens:

- Maximum and Average depth
- Dive number
- Date (dd-mon-yyyy)
- Start - Time of day dive started
- End - Time of day dive ended
- Length of dive in minutes
- Minimum, maximum, and average temperature
- Dive mode (Air, Nitrox, etc.)
- Surface interval preceding the dive
- Recorded Surface Pressure at the beginning of the dive
- Gradient factor settings used
- Start and end CNS
- Start and end pressure for up to 4 AI transmitters

#### Edit Log:

Scrolling past all screens of an individual log brings up the Edit Log page where Dive number, Date, and Time can be changed, or the dive log can be deleted.

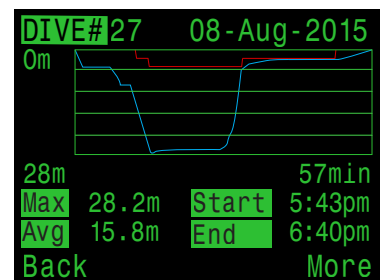
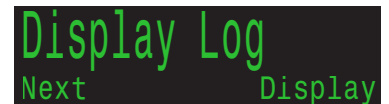

### 6.21.2 O2 Cal. History

This menu keeps a history of external O2 cell calibrations to make it easier to monitor cell health.

Each line in the main history represents an O2 calibration event. In the first column "P" means that the calibration passed, and "F" means the calibration failed.

The recorded mV value for each cell is shown here adjusted to sea level so the values can be usefully compared even if calibration occurred at different altitudes.

Viewing a calibration record displays more information about that specific calibration.

Calibrations can be deleted in this last screen to maintain a clean calibration history.

Deleted calibration logs can be restored using the restore mode function.

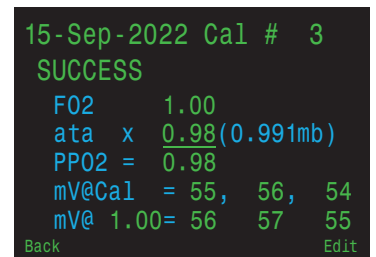
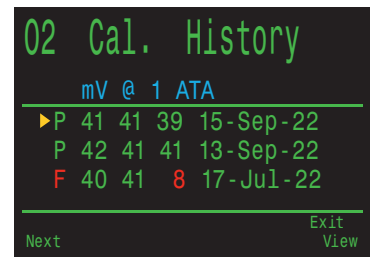
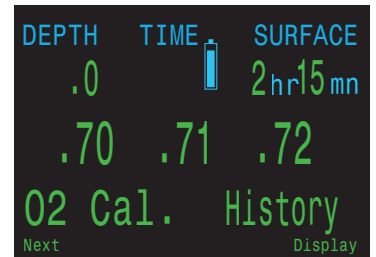

### 6.21.3 Next Log

The dive log number can be edited. This is useful if you want the dive computer log numbers to match your lifetime dive count.

This number will be applied to the next dive.

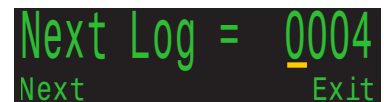

### 6.21.4 Restore Mode

Restore mode can be toggled on and off. When toggled on, it shows deleted logs and calibrations, grayed out in the "Display Log" and "O2 Cal. History" sub-menus. While in restore mode, these records can be restored.

The Delete All Logs option is also changed to Restore All Logs when Restore mode is enabled.



### 6.21.5 Delete All Logs ●●●

Deletes All of the Logs.

Deleted Logs can be restored by toggling Restore Mode to on.



### 6.22 Start Bluetooth ●●●

Bluetooth is used for both firmware uploading and dive log downloading. Use this option to initialize Bluetooth on your controller.



### 6.23 Reset Stack Time ●●●

This menu item allows to manually reset the stack time when changing the scrubber stack.

This menu screen is only available when the stack timer is enabled

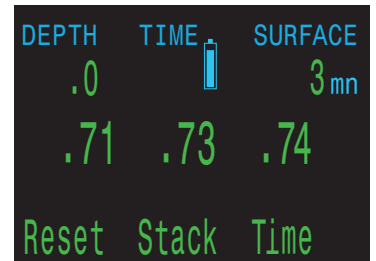

### 6.24 Setpoint -> .19 ●●●

Pressing SELECT when this menu is displayed changes the PO2 setpoint to 0.19. This menu is only available when on the surface.

This feature is provided as a convenience to prevent the solenoid from firing when setting up the rebreather on your workbench. There is very little room for error with a 0.19 setpoint, so it should never be used when breathing on the loop.

If a dive begins on the 0.19 setpoint, the setpoint is automatically switched up to the low setpoint.

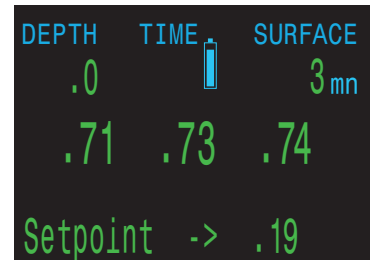

Save your life! NEVER breath on the loop when setpoint is 0.19:

There is very little room for error with a 0.19 PO2 setpoint. A small drop in PO2 could lead to hypoxia, which is a leading cause of rebreather fatalities and can be just as deadly on the surface as underwater.

The 0.19 setpoint is only for use during setup and transportation.

## 6.25 System Setup

Using this menu item it is possible to access a range of submenus for the basic configuration of the controller. This menu item, as well as all of the submenus contained within it, are unavailable in dive mode. As such, basic configuration of the controller can only be carried out at the surface.

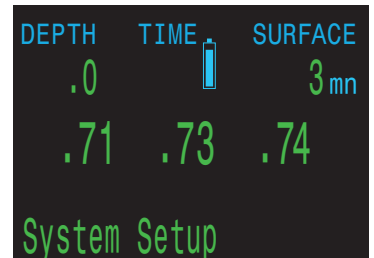

All of the settings available in Dive Setup are available in System Setup which can be accessed during a dive. However, not all settings in System Setup can be edited in Dive Setup.

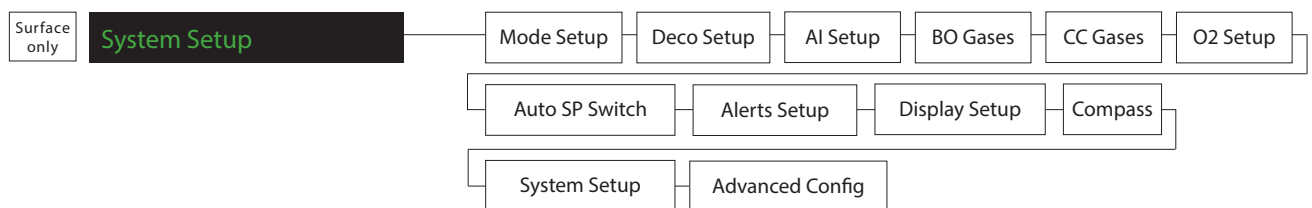

### 6.25.1 Mode Setup (Overview)

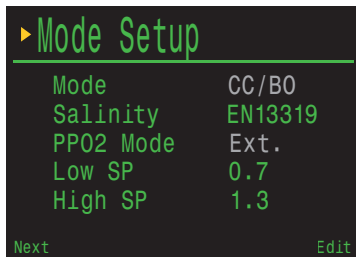

The first submenu of the system setup is "Mode Setup". The options "Low SP" and "High SP" are identical to those in the dive setup menu.

- The options "Mode" and "PO2 Mode" can't be edited because they are fixed and appear grayed-out.

### 6.25.2 Salinity (Mode Setup)

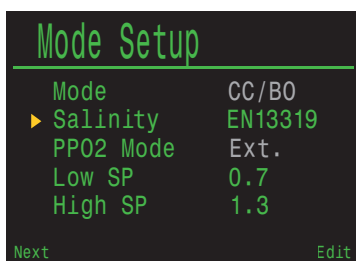

Water type (salinity) affects how the measured pressure is converted to depth.

Setting	Description
EN13319	The EN13319 value is between Fresh and Salt. It is from the European CE standard for dive computers, and is the controller's default value
Fresh	Fresh water
Salt	Salt water

- Fresh and Salt water differ by about 3%. Salt water, being denser, will display a shallower depth for the same measured pressure versus the Fresh water setting.
- The setting only has an impact for the displayed depth. It has no impact on the decompression calculation.

### 6.25.3 Low and High Setpoints (Mode Setup) ●●●

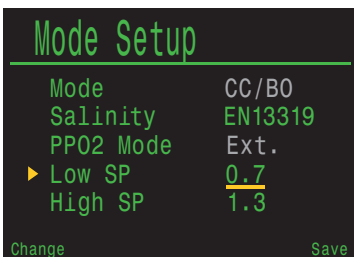
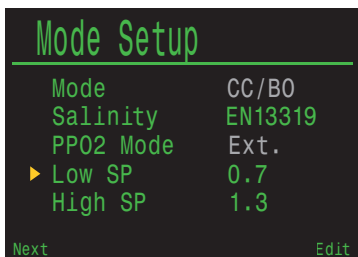

Each setpoint can be set from 0.5 to 1.5.

The setpoints can also be edited, even during a dive, in the Dive Setup menu.

### 6.25.4 Deco Setup (Overview) ●●●



Using this menu item it is possible to define various parameters for the decompression calculation.

By default this will show "Buhlmann GF ZHL16C" indicating that the Buhlmann ZHL-16C with gradient factors model is being used.

An optional VPM-B decompression algorithm unlock is available at an additional cost. If applied, the deco model item allows the user to change between the available algorithms.

### 6.25.5 Conserv. (Deco Setup) ●●●



Using this menu item it is possible to set the conservatism for the calculation of the decompression based on gradient factors (low and high).

- These settings can have a massive effect on the decompression calculations of the controller!
- If the diver does not know what effects these settings will have, no setting adjustments should be made for safety reasons!
- In order to understand the settings the diver must be aware of the theory of the gradient factors, M-values, inert gas pressure, etc!

### 6.25.6 Last Stop (Deco Setup) ●●●



Using this menu item it is possible to define the depth of the last decompression stop. It is possible to set the last decompression stop at either 3 or 6 metres.

### 6.25.7 NDL Display (Deco Setup)

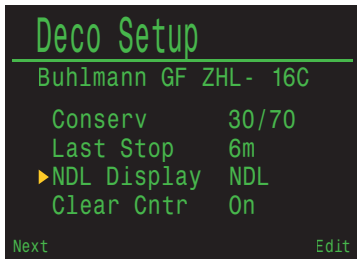

The NDL display options are identical to those in the dive setup menu:

- NDL
- CEIL
- GF 99
- @+5
- Δ+5
- MINI

See the dive setup menu for a more precise explanation of the options.

### 6.25.8 Mini NDL Display (Deco Setup)

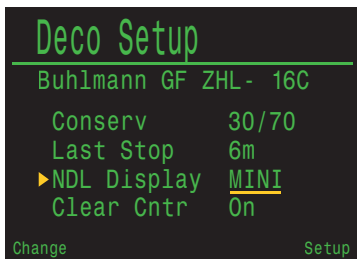

The controller has an NDL mini display function that can only be configured from the Deco Setup menu. This option allows 2 pieces of custom information to be displayed in addition to TTS by reconfiguring the layout of the normal NDL and TTS location.

When the Mini option is selected for the NDL Display, a configuration menu will appear. This menu allows the user to change the middle and bottom mini display options. The first row of this mini display is fixed as TTS.

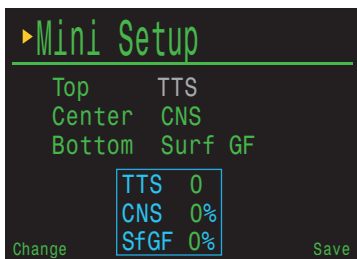

When the NDL mini display option is in use, NDL is displayed in place of the decompression information in the top row while there is no decompression obligation.

### 6.25.9 Clear Cntr (Deco Setup)

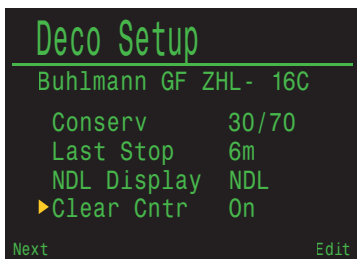

This option allows you to toggle the deco clear counter on or off.

When turned on, the counter will count up from zero in the deco area starting when decompression obligations are cleared.

## 6.25.10 AI Setup (Overview)

Please refer to the Shearwater SWIFT manual for further informationen about the "Air Integration" features and functions.

- Set AI Mode to OFF when AI not in use!

### NOT SUPPORTED:

The AI function is currently not supported by JJ-CCR ApS. The JJ-CCR rebreather is fully certified to a depth of 100 meters. Were as the controllers air integration system is under EN 250 certified for use with air only to a maximum depth of 50 meters. Furthermore the two pressure gauges are part of the rebreather's CE certification and a removal voids the CE.

### 6.25.11 BO Gases ●●●

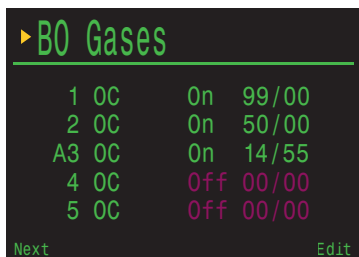

This menu allows the user to edit the open circuit bailout gas list. The options contained here are the same as those in the "Define Gases" subsection of the "Dive Setup" section. This menu page conveniently displays all five gases simultaneously.

Each gas can be turned on or off and set to any concentration of O2 and helium. The remaining percentage is assumed to be nitrogen.

The active gas is shown with a leading 'A'. All gases that are turned off are drawn in magenta (purple).

### 6.25.12 CC Gases ●●●

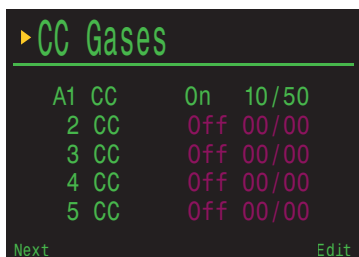

This menu allows the user to edit the closed circuit diluent gas list. The options contained here are the same as those in the BO Gas list setup menu.

### 6.25.13 O2 Setup (Overview) ●●●

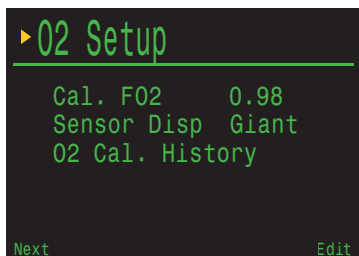

This menu allows the user to set the fraction of oxygen (FO2) of the calibration gas and sensor display mode and display the O2 calibration history.

### 6.25.14 Cal. FO2 (O2 Setup) ●●●

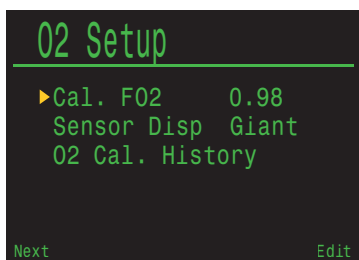

Using this menu item it is possible to change the fraction of oxygen (FO2) of the calibration gas. The calibration gas FO2 can be set from 0.70 to 1.00

- If 100% oxygen is used, an FO2 of 1.00 should be set for calibration.
- As soon as the FO2 has been changed and stored, calibration of the O2 sensors is invalid and "FAIL" appears on the display in place of a number for all three sensors. PO2 values are only displayed once again after successful calibration!

6.25.15 Sensor Disp (O2 Setup) ●●●

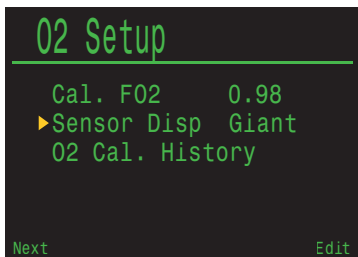

Sets the sensor display mode on the center row of the main screen. The available settings are:

Setting	Description
Large	The PO2 text is the normal large font.
Giant	The PO2 text is very large.

6.25.16 O2 Cal. History (O2 Setup) ●●●

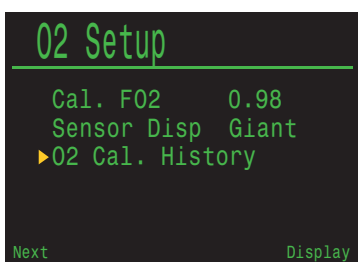

Displays the O2 calibration history. It is identical to the dive log menu.

6.25.17 Auto Setpoint Switch ●●●

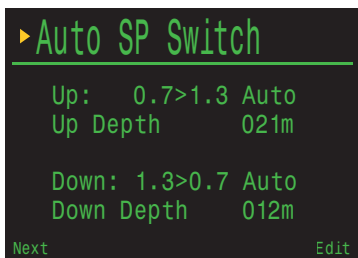

This page sets up automatic setpoint switching. The controller can be set up to auto switch the setpoint up only, down only, both, or neither.

First, you set whether the “Up” switch occurs automatically or manually. If “Up” is set to “Auto”, then you can set the depth at which the auto switch occurs.

The menu options are the same for the down setpoint switch.

When a switch is set to “Auto”, you can always manually override the setting at any time during the dive.

The automatic switches only occur when crossing the specified depth. Say for example, the switch up depth is set to 15m. You start the dive on the low setpoint, then as you descend past 15m, the setpoint automatically switches up to high. If at 24m you then manually switch back to the low setpoint, the setpoint will remain low. If you ascend shallower than 15m then re-descend deeper than 15m again, the automatic setpoint switch will occur again.

The controller enforces a 6m (20ft) gap between switch up and switch down depths to prevent rapid automatic switching between setpoints for small depth changes. The values 0.7 and 1.3 are shown as examples only. Other values for the low and high setpoint can be adjusted in the Dive Setup or Mode Setup menu.

### 6.25.18 Alerts Setup ●●●

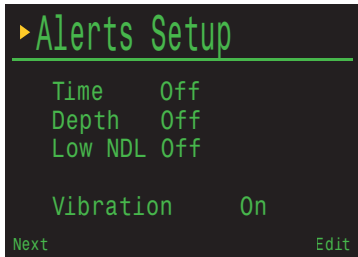

This page is used to set up custom dive alerts for Maximum Depth, Time, and Low NDL. Notifications will be triggered when these values are exceeded.

You can also toggle the vibration function from this page.

### 6.25.19 Display Setup (Overview) ●●●

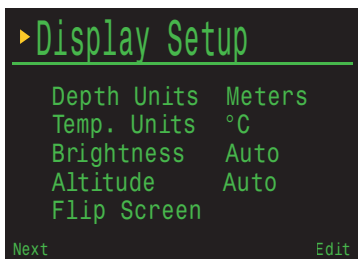

In this submenu it is possible to set all display options.

### 6.25.20 Depth Units (Display Setup) ●●●

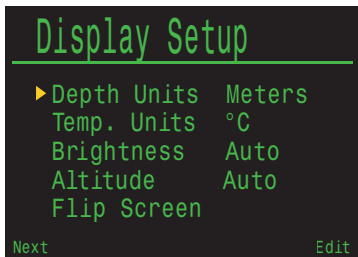

Via this menu item it is possible to switch the depth units between "Meters" and "Feet"

### 6.25.21 Temp. Units (Display Setup) ●●●

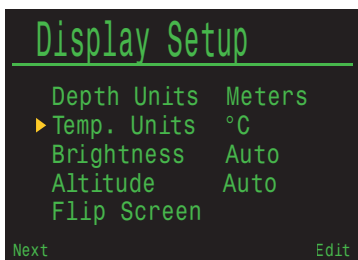

Via this menu item it is possible to switch the temperature between "°C" and "°F".

6.25.22 Brightness (Display Setup) ●●●

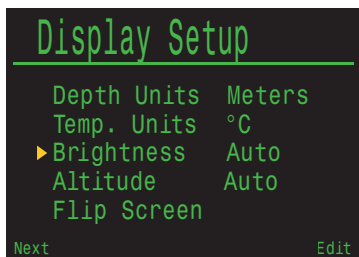

Using this menu item it is possible to set the brightness of the display.  
 The display brightness has four fixed brightness settings plus an Auto mode.  
 You can access the brightness settings also via the dive log menu.

Mode	Description
Auto	The light sensor measures the ambient light and automatically adjusts the brightness of the display.
Low	Permanent minimum brightness - Second longest battery life.
Med	Permanent medium brightness - Best mix of battery life and readability.
High	Permanent maximum brightness - Easiest readability, especially in bright sunlight.
Cave	Suitable for very dark environments like caves - Longest battery life.

- The “Auto” setting works well in most situations.
- The brightness of the display is the major determinant of battery life. Up to 80% of the power consumption is to power the display. When a low battery alert occurs, the display brightness is automatically reduced to extend battery life.

6.25.23 Altitude (Display Setup) ●●●

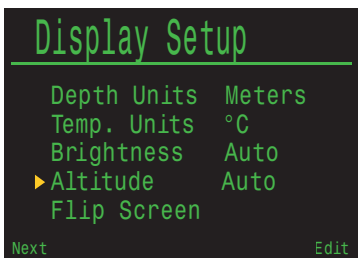

The altitude setting on the controller is set to Auto by default. In this mode the controller will automatically compensate for pressure changes when diving at altitude.

If all your diving is at sea level, then setting this to ‘SeaLvl’ will assume that surface pressure is always 1013 mbar (1 atmosphere).

- When surface pressure is less than 960 millibar, the controller forces the use of “Auto” altitude setting (i.e. cannot use the “SeaLvl” setting).

**Determination of Surface Pressure:**

Accurate depth measurements and decompression calculations require knowing the ambient atmospheric pressure at the surface. Regardless of the turn on method, the surface pressure is determined the same way. While in the off state the surface pressure is measured and saved every 15 seconds. A 10 minute history of these pressure samples is kept. Immediately after turn on this history is examined and the minimum pressure is used as the surface pressure. The surface pressure is then remembered, and not updated again until the next turn on.

### 6.25.24 Flip Screen (Display Setup) ●●●

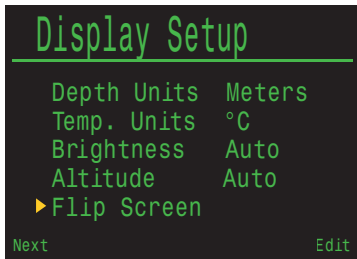

Via this menu item it is possible to flip the controller display through 180 degrees. The assignment of both buttons is also flipped through 180 degrees!

This is useful if you wish to wear your controller on the right arm.

### 6.25.25 Compass (Overview) ●●●

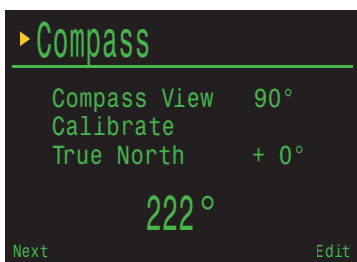

In this submenu it is possible to calibrate the compass and set all options for it.

### 6.25.26 Compass View (Compass) ●●●

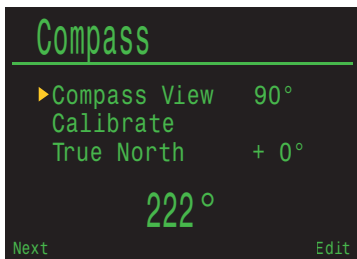

Via this menu item you can switch off the compass or change the compass dial that is visible on the main screen.

Setting	Description
Off	If the compass is set to off, then the compass display does not appear as the first info screen and the "Mark Compass" menu is not available.
60° / 90° / 120°	Sets the range of the compass dial that is visible on the main screen. The actual amount of arc that is shown on the screen is 60°, so this may seem the most natural. The 90° or 120° setting can be used to see a wider range.

## 6.25.27 Calibrate (Compass) ●●●

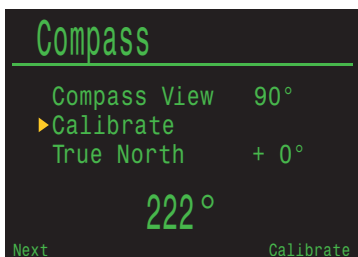

Via this menu item you can calibrate the compass or reset it to the factory settings. Calibration of the compass may be needed if the accuracy drifts over time or if a permanent magnet or ferromagnetic metal (e.g. iron or nickel) object is mounted very close to the controller. To be calibrated out, such an object must be mounted with the controller such that it moves along with the controller.

- Compare the controller with a known good compass or fixed references to determine if calibration is needed.
- If comparing against fixed references, remember to consider the local deviation between Magnetic North and True North (declination).
- Calibration is typically not needed when traveling to different locations. The adjustment needed then is the True North (declination).
- When calibrating, rotate the controller smoothly through as many 3D twists and turns as possible in 15 seconds.

### Calibrate the Compass Each Battery Change:

Each battery has its own magnetic signature, mostly due to its steel case. Therefore, recalibrating the compass when changing batteries is recommended.

### Compass Calibration Tips:

The following tips will help ensure a good calibration:

- Stay away from metal (especially steel or iron) objects. For example, wrist watches, metal desks, boat decks, desktop computers, etc. These can all interfere with the Earth's magnetic field.
- Rotate to as many 3D positions as possible. Upside down, sideways, on edge, etc.
- Compare with an analog compass to check calibration.

## 6.25.28 True North Declination (Compass) ●●●

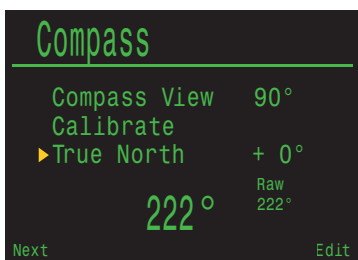

Allows to enter the declination of current position to correct compass to true north.

This setting can be set from -99° to +99°.

If matching an uncompensated compass, or navigation is based on relative directions, then this setting can be left at 0°

### 6.25.29 System Setup (Overview) ●●●

```

▶ System Setup
Date      09-Oct-2022
Clock     13:30 24h
Unlock
Log Rate  10 sec
Reset to Defaults

Next      Edit

```

In this submenu it is possible to implement various system settings.

### 6.25.30 Date (System Setup) ●●●

```

System Setup
▶ Date     09-Oct-2022
Clock     13:30 24h
Unlock
Log Rate  10 sec
Reset to Defaults

Next      Edit

```

Using this menu item it is possible to set the current date. The date is used for the controller logbook. The sequence is: day/month/year.

### 6.25.31 Clock (System Setup) ●●●

```

System Setup
Date      09-Oct-2022
▶ Clock   13:30 24h
Unlock
Log Rate  10 sec
Reset to Defaults

Next      Edit

```

Using this menu item it is possible to set the current time. The time is used for the controller logbook. The time can be displayed in AM/PM or as 24 hour format.

### 6.25.32 Unlock (System Setup) ●●●

```

System Setup
Date      09-Oct-2022
Clock     13:30 24h
▶ Unlock
Log Rate  10 sec
Reset to Defaults

Next      Edit

```

```

System Setup
Date      09-Oct-2022
Clock     13:30 24h
▶ 00000000000000000000
Log Rate  10 sec
Reset to Defaults

Change    Next

```

This menu item enables the entry of a code in order to release additional controller functions. (E.g. VPM decompression model).



6.25.33 Log Rate (System Setup) ●●●

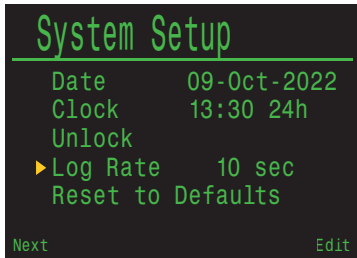

Sets how often dive samples are added to the controller’s log. More samples will give a higher resolution dive log at the expense of log memory. Default is 10 seconds. Maximum resolution is 2 seconds.

6.25.34 Reset to Defaults (System Setup) ●●●

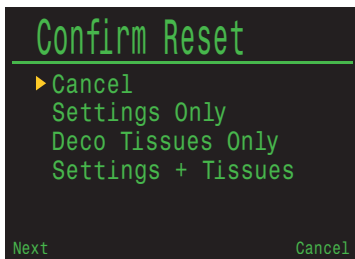
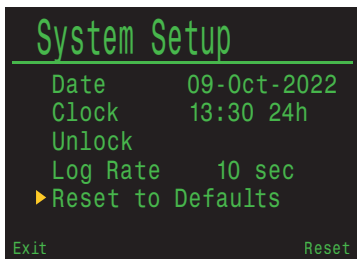

The option resets all controller settings to the factory settings. The reset needs to be confirmed and the user can select the following options:

- Settings Only
- Deco Tissues Only
- Settings + Tissues

- This option deletes neither the internal logbook nor the dive numbers.

6.25.35 Advanced Config (Overview) ●●●

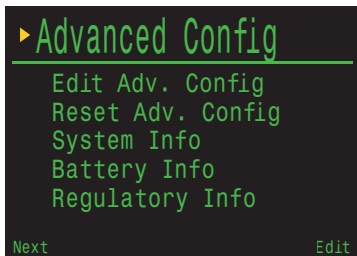

Advanced configuration contains items that will be used infrequently and can be ignored by most users. They provide more detailed configurations.

The first screen allows you to enter the advanced configuration area, or to set the advanced configurations settings to their default.

Note: This will not affect other computer settings, delete dive logs, or reset dive log numbers.

### 6.25.36 System Info (Advanced Config) ●●●

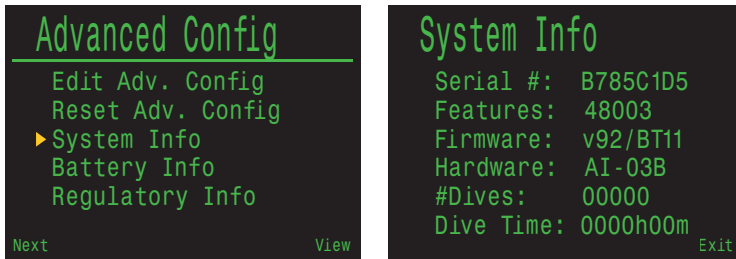

This option shows some additional system information:

Info	Description
Serial	The controller's serial number
Features	The controller's activated features
Firmware	The controllers firmware version
Hardware	The controllers mainboard revision
Dives	Total livetime dive count
Dive Time	Total livetime dive time in hours and minutes

### 6.25.37 Battery Info (Advanced Config) ●●●

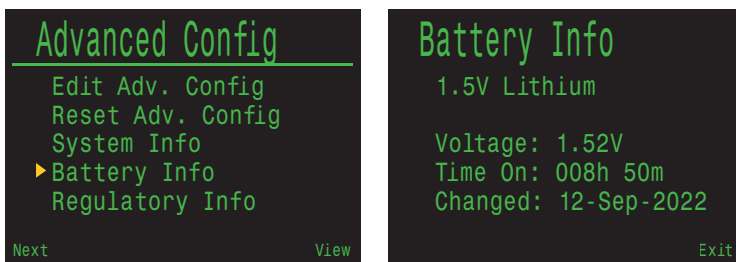

The battery info screen shows:

Info	Description
1.5V Lithium	Battery type
Voltage	Current voltage
Time On	Time on since last battery change
Change	Date of last battery change

### 6.25.38 Regulatory Info (Advanced Config) ●●●

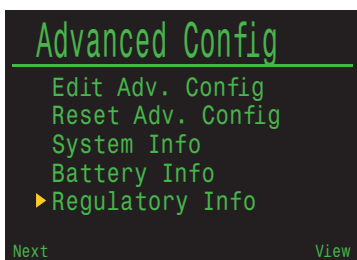

This section is where a user can find the specific model number of their computer as well as additional regulatory information.

6.25.39 Main Color (Advanced Config 1) ●●●

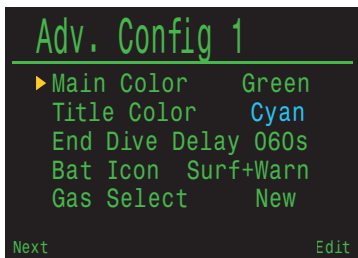

The main colours can be changed for added contrast or visual appeal.

The available colours are: green and red.

6.25.40 Title Color (Advanced Config 1) ●●●

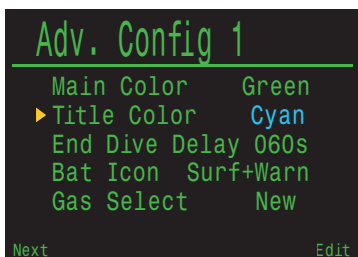

The title colours can be changed for added contrast or visual appeal.

The available colours are: cyan, blue, gray, white, green, pink and red.

6.25.41 End Dive Delay (Advanced Config 1) ●●●

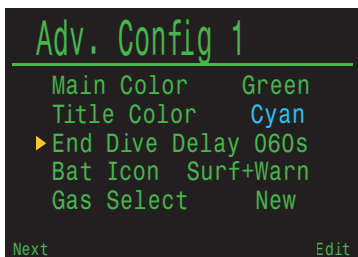

This option sets the time in seconds to wait before ending the current dive. This value can be set from 20 seconds to 600 seconds (10 minutes). The default value is 60 seconds. Since the controller can stay in dive mode for a longer time, a new “End Dive” menu option has been added. This is the first menu option when the controller is still in dive mode and when the diver is at the surface.

6.25.42 Bat Icon (Advanced Config 1) ●●●

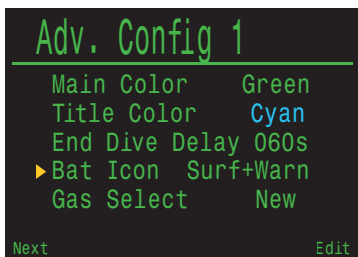

The behavior of the battery icon can be changed here. The available Options are:

Mode	Description
Warn Only	The battery icon only appears when there is a low battery warning (Default).
Always	The battery icon always displays.
Surf + Warn	The battery icon displays always when on the surface. During dive it displays only if there is a low battery warning.

6.25.43 Gas Select (Advanced Config 1) ●●●

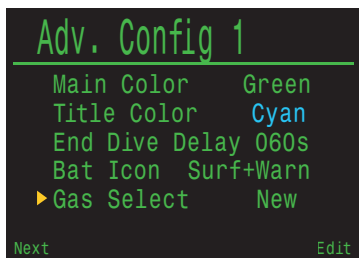

This option allows to change the style of the "Select Gas" menu. You can choose between the "Classic" and "New" style. The classic style shows one gas with a big font. The new style shows all gases at the same time with a small font.

6.25.44 Advanced Config 2 (PO2 Limits) ●●●

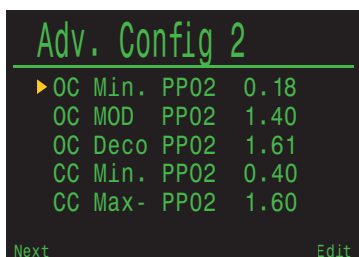

The "Advanced Config" page 2 allows the changing of the PO2 limits.

**WARNING: Do not change these values unless you understand the effect**

- A "Low PO2" or "High PO2" alert is displayed when the limits are violated for more than 30 seconds.

Setting	Description
OC Min. PO2	PO2 displays in flashing red when less than this value. The default is 0.18.
OC MOD PO2	PO2 displays in flashing red when higher than this value. The default is 1.61.
OC Deco PO2	The decompression predictions (TTS and NDL) will assume that the gas in use at a given depth is the gas with the highest PO2 that is less than or equal to this value. Also, the suggested gas switches (when the current gas is displayed in yellow) are determined by this value. If you change this value, please understand its effect. For example, if lowered to 1.50, then oxygen (99/00) will not assumed at 6m. The default is 1.61.
CC Min PO2	PO2 displays in flashing red when less than this value. The default is 0.40.
CC Max. PO2	PO2 displays in flashing red when higher than this value. The default is 1.60.

6.25.45 Advanced Config 3 (Button Sensivity) ●●●

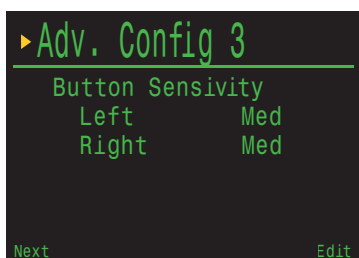

This menu allows some fine tuning of button sensitivity. This can be useful to adjust downward if you often experience accidental button presses.

6.25.46 Advanced Config 4 (Stack Timer) ●●●

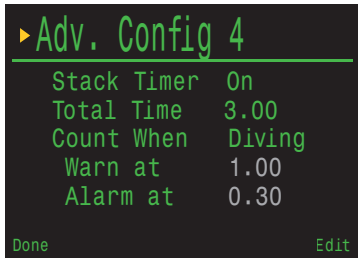

The "Advanced Config 4" allows to configure the "Stack Timer" (CO2 scrubber duration timer).

Setting	Description
Stack Timer	Toggles the "Stack Timer" on or off
Total Time	The total time can be set anywhere between 1h and 9h 59m.
Stack Timer	The stack timer can be set to count down either when diving, or when the computer is ON.
Warn at	Not changeable - Shows a warning when stack time is less than 1 h.
Alarm at	Not changeable - Show an alarm when stack time is less than 30m

6.26 Bus Devices ●●●

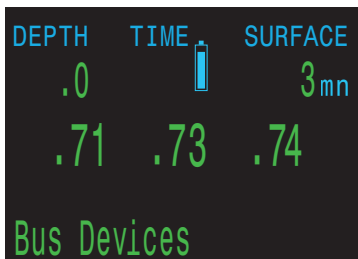

The "Bus Devices" info screen shows a list of all DiveCan® devices. It also allows changing settings on peripheral boards. For example, on the SOLO board (solenoid and oxygen controller) the Solenoid Speed setting can be adjusted.

### 6.26.1 SRI Petrel (Bus Devices) ●●●

```

Bus Devices
▶ SRI Petrel 3 V92
  SRI Solo 2 V09

Exit View

```

```

Petrel 3
-----
Firmware: V92
No Options

Exit

```

The Petrel is not a peripheral board and there are no options available.

### 6.26.2 SRI SOLO (Bus Devices) ●●●

```

Bus Devices
  SRI Petrel 3 V92
▶ SRI Solo 2 V09

Exit View

```

```

Solo 2 AB000EDE
-----
Firmware: V09
▶ Solo_Speed PID_5SEC
PIC VER 14

Next Edit

```

On the SOLO board (solenoid and oxygen controller) the Solenoid Speed setting can be adjusted.

Solenoid speed setting can be set to either the 1 second or 5 second PID control algorithm. This feature is comparable with the "slow" and "fast" solenoid setting, which was available on the classic JJ-CCR (Shearwater Predator based controller). The setting is edited on the controller, but are stored in the SOLO board.

The 5 second PID control algorithm is the default setting. With the 1 second PID control the PO2 can be more precisely maintained but the solenoid is operational more often in order to constantly supply small volumes of oxygen. This results in much higher use of the battery. Many divers also find the constant operating noise of the solenoid annoying.

## 6.27 Changing the battery ●●●

NOTE: A large coin or washer is required for this section.

- 1.Remove the battery cap: Insert the coin or washer into the battery cap slot. Unscrew by turning counter clockwise until the battery cap is free. Be sure to store the battery cap in a clean dry space.
- 2.Exchange the battery: Remove the existing battery by tilting the controller and letting the old battery slide out. Insert a new battery positive contact first. A small diagram on the bottom of the controller shows the proper orientation
- 3.Reinstalling the battery cap: It is very important that the battery cap O-rings are clear of dust or debris. Carefully inspect the O-rings for any debris or damage and gently clean. It is recommended that the battery cap's O-ring is lubricated on a regular basis with an O-ring lubricant compatible with Buna-N (Nitrile) O-rings. Lubricating helps ensure that the O-ring seats properly and does not twist or bunch.

Insert the battery cap into the controller and compress the battery contact springs. While the springs are compressed rotate the battery cap clockwise to engage the threads. Be sure not to cross thread the battery cap's threads. Tighten the battery cap until snug and the controller powers on. Do not over tighten the battery cap.

IMPORTANT: Replace the o-ring at least once a year or after every 3 battery changes!

### 6.27.1 Battery Type Selection ●●●

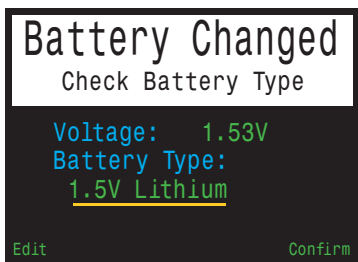

After changing the battery, select the battery type used.

The controller attempts to guess what type of battery is being used. If the battery type is incorrect, it should be manually edited.

The controller can accept most AA sized (14500 size) batteries that output a voltage between 0.9 V and 4.3V. However, some batteries are better than others.

- Not all batteries support vibration.
- Battery types that support the fuel gauge feature will give more warning before the computer dies.
- Some battery types perform better in cold water.

Shearwater recommends using Energizer Ultimate Lithium batteries for best performance.

The following table and values are from Shearwater and show the supported battery types:

Battery Type	Approx. Battery Life	Vibration Support	Fuel Gauge	Cold water Performance
1.5V Lithium	60 hours	Yes	Yes	Very Good
1.5V Alkaline	45 hours	No	Yes	OK
1.2V NiMh Rechargeable	30 hours	No	No	Poor
3.6V SAFT LS14500	130 hours	No	No	Poor
3.7V Li-Ion Rechargeable	35 hours	Yes	Yes	Good

- Note: Battery operating lifetimes are given with screen on medium brightness and at room temperature. Higher brightness and lower temperature can reduce life. Lower brightness can increase life.

Alkaline batteries are not recommended:

Alkaline batteries are especially prone to leaking. This is a leading cause of dive computer failure.

## 6.27.2 Behavior on Battery Change

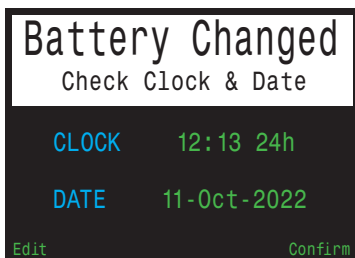

Settings:

All settings are retained permanently. No loss of settings occurs when changing the battery.

Clock:

The clock (time and date) is saved to permanent memory every 16 seconds when the dive computer is on, and every 5 minutes when off. When the battery is removed, the clock stops running. Once the battery is replaced, the clock is restored to the last saved value (so it is best to remove the battery while the dive computer is on for lowest error).

Quick battery changes will not require any adjustment, but the time should be corrected if the battery is removed for more than a few minutes.

Expected clock drift is about 4 minutes per month. If there is higher drift, it is likely due to clock stoppage during battery changes, and is easily corrected at the time of a battery change.

The clock is also updated every time the dive computer is connected to Shearwater Cloud Desktop or Shearwater Cloud Mobile.

## 6.28 Firmware Update and Log Download ●●●

It is important to keep the firmware on your rebreather controller up to date. In addition to new features and improvements, firmware updates address important bug fixes

There are two ways to update the firmware on your controller:

- 1. With Shearwater Cloud Desktop
- 2. With Shearwater Cloud Mobile

Upgrading the firmware resets decompression tissue loading. Plan repetitive dives accordingly.

During the update process, the screen may flicker or go blank for a few seconds.

### 6.28.1 Shearwater Cloud Desktop ●●●

Ensure you have the most recent version of Shearwater Cloud Desktop. The software can be downloaded for free from the Shearwater homepage.

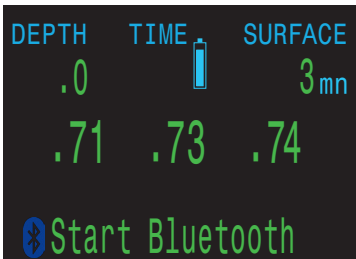

Connect to Shearwater Cloud Desktop:  
On your controller, start Bluetooth by selecting the Bluetooth menu item from the main menu.

In Shearwater Cloud Desktop:

- 1. Click the connect icon to open the connect tab.
- 2. Scan for Dive Computer
- 3. Once you've connected the computer once, use the Petrel 3 tab to connect faster next time

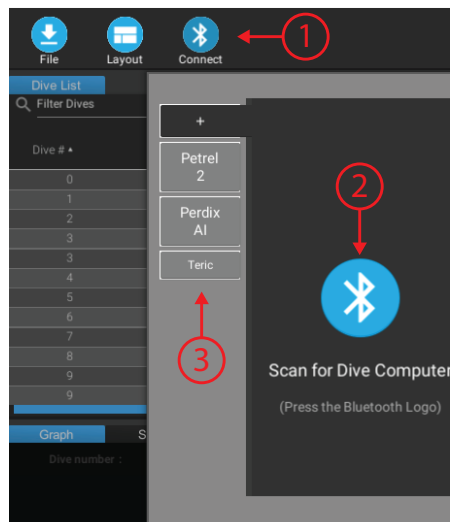

Once the controller is connected, the connect tab will show a picture of the dive computer.

**Download Dives:**

Select "Download Dives" from the connect tab.

A list of dives will be generated. You can un-select any dive logs you don't want to download, then press OK.

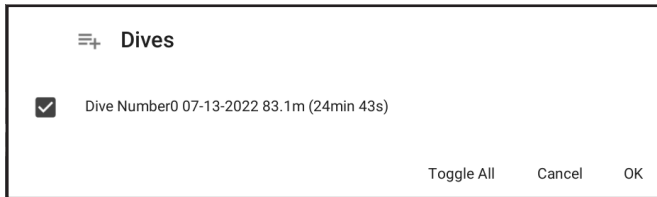

Shearwater Cloud Desktop will transfer the dives to your computer.

From the connect tab, you can give the controller a name. If you have multiple Shearwater dive computers, you will be able to easily tell which dive was downloaded from which dive computer.

**Update Firmware:**

Select "Update Firmware" from the connect tab.

Shearwater Cloud Desktop will automatically select the latest available firmware.

When prompted, select your language and confirm the update.

The controller screen will give percentile updates of receiving the firmware, and then the Personal Computer will read "Firmware successfully sent to the computer" on completion.

Firmware updates can take up to 15 minutes.

**Update Start-up Text:**

Start-Up text appears at the top of the start up splash screen when the controller is turned on. It's a great place to put your name and phone number so your computer can be more easily returned if mis-placed.

**Update Start-up Image:**

Here you can also change the startup image that appears when the controller turns on to help better differentiate your dive computer.

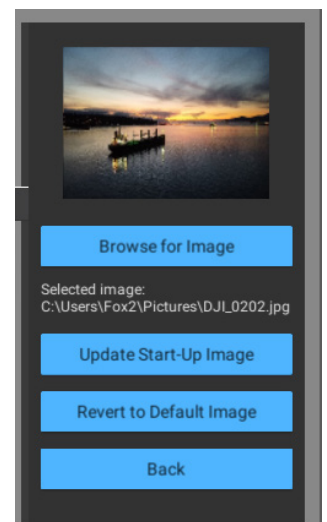
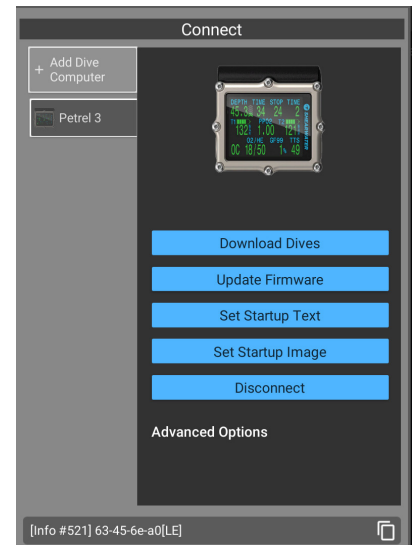

## 6.28.2 Shearwater Cloud Mobile ●●●

Ensure you have the most recent version of Shearwater Cloud Mobile. The software can be downloaded for free from Google Play or Apple App Store



Connect to Shearwater Cloud Desktop:  
On your controller, start Bluetooth by selecting the Bluetooth menu item from the main menu.

In Shearwater Cloud Mobile:

- 1.Press the connect icon at the bottom of the screen
- 2.Select your Petrel 3 from the list of Bluetooth devices

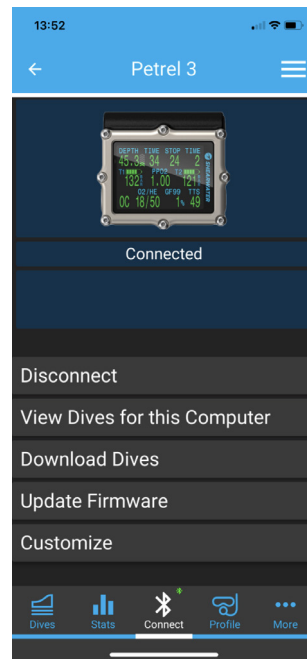
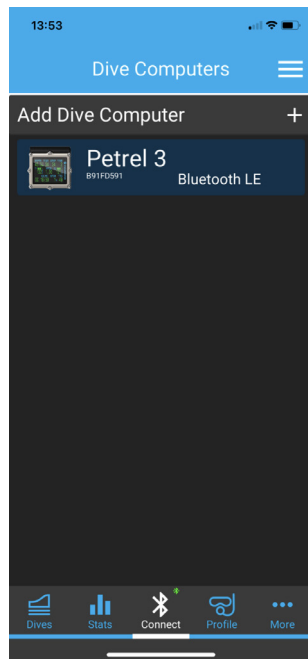

Download Dives:  
Select "Download Dives"

A list of dives will be generated and you can un-select any dive logs you don't want to download, then press OK.

Shearwater Cloud will transfer the dives to your smart phone.

Update Firmware:  
Once the Petrel 3 is connected to Shearwater cloud mobile, select "Update Firmware" from the connect tab.

Shearwater Cloud mobile will automatically select the latest available firmware.

When prompted, select your language and confirm the update.

The controller screen will give percentile updates of receiving the firmware, and then the mobile app will read "Firmware successfully sent to the computer" on completion.

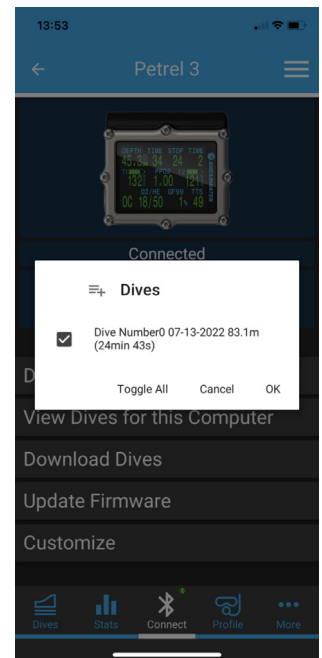

## 7 Checklist prior to diving



This chapter contains a complete checklist for the JJ-CCR Rebreather prior to a dive. It is essential that the diver run through this checklist prior to every dive.

- If the diver does not run through the checklist then there is a possibility of entering the water with equipment that is not suitable for diving, which can result in severe risks to health.

### 7.1 Preparations on land



Step	Description
1	Do I feel, healthy, well and calm? If not, it is best not to dive!
2	Is the soda lime canister filled with new soda lime that has never been used? Soda lime that has already been used must never be used for another dive.
3	Analyse the contents of the diluent and oxygen cylinders. Also check whether sufficient pressure is present for the planned dive.
4	Never forget to carry an adequate Bailout system for the dive. When calculating the required Bailout system, always assume the worst case scenarios. You can never take too much Bailout gas with you!
5	Secure the cylinders (O <sub>2</sub> and diluent) to the Rebreather.
6	Place the lid with the soda lime canister into the aluminium housing.
7	Connect all hoses. Take care to ensure that the O-rings are clean. Always check that the DSV shutter valves are functioning correctly in the breathing hose.
8	Open both cylinder valves and check the cylinder pressure.
9	Check the medium pressure of both first stages. The diluent must exhibit a medium pressure of 9.0 to 10.0 bar, whilst in the case of the oxygen this must be 7.0 – 7.5 bar. It is prohibited to dive using the equipment if these values are not correct!
10	Check the manual supplemental valves and ADV to ensure they are functioning correctly.
11	Check the wing inflator to ensure it is functioning correctly.
12	Check the DSV (Dive Surface Valve) to ensure it is functioning correctly.
13	Carry out a positive pressure test: Fill the circuit fully with air via the mouthpiece, until the overpressure valve of the counter lung triggers. Close the mouthpiece and wait a few minutes. Now open the mouthpiece again. If the system still contains overpressure then you will hear the gas escaping upon opening the mouthpiece.
14	Actuate the fast drain valve on the counter lung in order to ensure that it functions correctly.
15	Carry out a negative pressure test: Close both cylinder valves. Using the mouthpiece, generate a vacuum in the circuit. A clear sign of a vacuum is the position of the ADV membrane. Close the mouthpiece and wait. If the position of the ADV membrane does not change, the test has been successful. As soon as you open the mouthpiece again you should also hear the noise of air being drawn in.

16	Open both cylinder valves again.
17	Open the mouthpiece (=CC mode).
18	Switch the HUD and the controller on.
19	Calibrate the oxygen sensors with the controller and then with the HUD.
20	Check to voltage of the controller and solenoid battery.
21	Breathe for 2-3 minutes from the device, in order to check that the soda lime is functioning correctly.
22	Close the mouthpiece (OC mode).
23	Switch off the controller and the HUD.
24	Close both cylinder valves.

## 7.2 Shortly prior to diving



Step	Description
1	Open both cylinder valves and check the cylinder pressure.
2	Check the manual supplemental valves and the ADV.
3	Check the wing inflator.
4	Check the DSV (Dive Surface Valve) to ensure it is functioning correctly.
5	Carry out a positive and negative pressure test.
6	Switch the HUD and the controller on.
7	Check the setting of the low and high setpoint on the controller.
8	Open the mouthpiece and breathe for at least 2-3 minutes.

## 7.3 Shortly after entering the water



Step	Description
1	Carry out a bubble check within the first 6 metres of descending. Never start a deeper descent without carrying out this check.
2	Check the display on the controller and HUD.
3	Check that the equipment is correctly positioned and that everything is stored in the right place.

## 8 Diving



The most important rule when diving is: Always know your PO<sub>2</sub> at all times! With the JJ-CCR this can be read out from the HUD and/or the controller. In order to be certain that both systems are working correctly, the diver should also check regularly to ensure that both instruments are displaying the same values. The optimum water position requiring the minimum breathing effort is at an angle of 20 - 30 degrees. This means that the head must be somewhat higher than the legs. Breathing should be deep and even at all times. In general terms, the volume in the breathing circuit should be as low as possible. Too great a volume has a negative effect on the breathing effort and buoyancy. The volume in the breathing circuit is perfect if breathing in does not quite trigger the ADV.

## 9 After the Dive



This chapter contains details of all steps that should be carried out with the JJ-CCR Rebreather after the dive. Please carry out these steps after every dive:

Step	Description
1	Never close the cylinder valves before you take off the Rebreather.
2	Switch the controller off and dry the water contacts.
3	Switch off the HUD.
4	Close both cylinder valves.
5	Remove the breathing hose with the DSV.
6	Remove the lid with the soda lime canister from the aluminium housing.
7	Remove the soda lime canister from the lid.
8	Leave the lid and the soda lime canister to dry.

Steps 5-8 are only necessary if the diver is planning no further dives the same day.

### 9.1 Transportation



The rebreather should stand up during transportation after use to allow eventual condensate water inside the unit to drain to the bottom of the counter lungs, loop, and canister.

## 10 Cleaning

It is possible to carry out "quick" or "complete" cleaning of the JJ-CCR Rebreather. "Quick" cleaning is completed rapidly and can also be carried out between two dives.

### 10.1 "Quick" Cleaning

The following steps should be carried out for "quick" cleaning:

Step	Description
1	Remove the breathing hose with the DSV and rise it with water. Attention: Excessive water pressure must be avoided as this can damage the shutter valves.
2	Add water to the counter lung via the T-piece – ATTENTION ONLY ON THE EXHALATION SIDE. Remove the water by actuating the fast drain valve.
3	Remove the lid with the soda lime canister from the aluminium housing.
4	Remove the soda lime canister from the lid.
5	Leave the lid and the soda lime canister to dry.

### 10.2 "Complete" Cleaning

Complete cleaning should be carried out every day, in particular in warmer regions.

Step	Description
1	Remove the lid with the soda lime canister from the aluminium housing.
2	Remove the soda lime canister from the cap.
3	Leave the lid and the soda lime canister to dry.
4	Remove the counter lung with the breathing hose.
5	Spray a little disinfectant (e.g. JJ-CCR Clean) into the T-pieces.
6	Fill the counter lung and breathing hose with water and wait a few minutes (in accordance with the specifications for the disinfectant).
7	Empty the counter lung and breathing hose. Rinse everything once more with fresh water. The simplest way to do this is to remove the breathing hose from the counter lung and rinse both through separately.
8	Leave everything to dry overnight. The counter lungs dry best if rotated 180 degrees and hung up, so that the T-pieces point downwards.

Two short hoses are located on the lid. It is not necessary to clean these so frequently. This can be carried out after a period of a number of weeks without cause for concern. It is important that the lid is always stored such that these two hoses are able to dry out well during a dive. If necessary it is also possible to rinse the hoses out on the exhalation side using water. In order to do so, hold the lid at a slight angle so that the water can drain out directly. Never rinse the inhalation side in the same way because the oxygen sensors will be immersed in water. When carrying out complete cleaning it is naturally also possible to remove both hoses. In order to do so, remove the screw with the washer located between the two hoses. (see chapter 5.1.4)

## 11 Storage ●●●



When storing the JJ-CCR Rebreather it is essential to choose a dry, shady and well ventilated location. Avoid any unnecessary UV radiation. All parts of the breathing circuit must be disinfected thoroughly prior to storage, and the soda lime canister must be emptied. In order to prevent the penetration of living creatures and/or other foreign particles, the equipment must be assembled for storage. Ensure that the DSV (Dive Surface Valve) is closed. The lid with the soda lime canister must not be placed fully in the aluminium housing. The image on the left shows the correct position:

If the lid is inserted fully with the soda lime canister and remains in this position for an extended period then it is possible, in certain circumstances, that it will be necessary to apply extensive force in order to remove it.

## 12 Maintenance

### 12.1 General Care

As with all technical equipment, the JJ-CCR Rebreather should always be treated with care. General care also includes observing the maintenance intervals and regularly checking the general condition of the equipment. For example, the O-ring grease.

### 12.2 Maximum Service Life

If the maintenance intervals are observed, there is theoretically no given maximum service life. However, the user should be aware that rubber and plastic parts do age, and that this process is accelerated by exposure to direct sunlight. If these parts are not replaced during standard maintenance works then the following maximum service life figures apply:

Service life	Part(s)
10 years	All rubber parts – Breathing hose, mouthpiece, O-rings, etc.
10 years	Counter lungs – without outer liners
10 years	Diluent hoses – High pressure and middle pressure
5 years	Oxygen hoses – High pressure and middle pressure
1 year	Oxygen sensors (Max. operating life after installation)

Decisive here is the production year of the equipment. This information can be found on the type plate. For example "Mfg Date: 11/07" stands for the year 2011 and the month of July. If the parts have not been replaced at an earlier date during maintenance then they must be replaced no later than upon reaching this date. Exceptions here are the oxygen sensors: Maximum sensor life is 15 months from date of manufacture but only 12 months of use in the rebreather.

### 12.3 Approved care products

The following care products can be used:

Care product	Description
Grease	Molykote 111: Can be used for greasing all breathing circuit elements. ChristoLube MCG 111, Tribolube 71 or Halocarbon 25-5S: Can be used for greasing all breathing circuit elements and all parts conducting at medium pressure.
Desinfection	<ul style="list-style-type: none"> <li>Chemgene MedLab Multi-Surface Disinfectant</li> <li>Virkon S</li> <li>Steramine 1G</li> </ul> <p>Follow the directions for use supplied with the disinfectant used.</p>
Cleaning	For general cleaning (e.g. after use in seawater) normal tap water should be used.

## 12.4 Care Intervals

The following equipment care intervals must be adhered to:

### 12.4.1 Prior every dive

When assembling the equipment ensure in particular that all connections are free of impurities. If necessary, grease the O-rings. Do not use excessive grease. It is sufficient for the O-rings to exhibit a fine sheen. Check the correct function of the equipment in accordance with chapter 7.

- Defective and/or worn out parts must be replaced immediately.
- If the equipment is not fit for operation according to the checklist (chapter 7) then under no circumstances should it be used.

### 12.4.2 After every dive

Clean the equipment after every dive in accordance with chapter 10. It is necessary to carry out quick or complete cleaning depending on the situation. If the equipment has been used in salt water or chlorinated water, then it must be cleaned with fresh water before being disassembled for cleaning.

- Complete cleaning should take place shortly after the dive and no later than 12 hours afterwards.
- If used within chlorinated water (swimming pool), it has to be cleaned with fresh water right away.

## 12.5 Maintenance Intervals

The JJ-CCR Rebreather must be maintained in accordance with the maintenance intervals specified.

- The user is permitted to replace the O-rings for the breathing circuit, the lid, base plate, shutter valves, oxygen sensors and membrane for the ADV. The equipment must be returned to the manufacturer or an approved service centre for all other work.
- Maintenance and repairs to the solenoid, electronics and the first stage must be carried out by the manufacturer or an approved service centre exclusively.
- In the event of repairs only use original replacement parts. If other parts are used then the warranty is voided and there is a risk that a malfunction could result in injury or even death.
- The individual maintenance intervals are based on normal use. In the event of more intense use, these intervals must be reduced. It is therefore necessary to replace defective and/or worn out parts immediately, irrespective of the maintenance intervals.

### 12.5.1 Every 12 months



Part or Assembly	Maintenance Task
Oxygen sensors	Replace all oxygen sensors which are in use after 12 months since installation.
1 <sup>st</sup> stage diluent 1 <sup>st</sup> stage oxygen	Revision of the 1 <sup>st</sup> stage for the diluent and the 1 <sup>st</sup> stage for the oxygen.
Medium pressure hoses High pressure hoses	Check all medium and high pressure hoses
Breathing circuit	Replace all O-rings at the connections with the T-piece and ADV. This applies to the breathing hose with the DSV and the two breathing hoses from the lid.
DSV (Dive Surface Valve)	Exchange the shutter valves.

### 12.5.2 Every 24 months



Part or Assembly	Maintenance Task
Lid	Replace three O-rings (2 x lid seal, 1 x soda lime canister seal)
Base plate	Replace both O-rings
Diluent cylinder Oxygen cylinder	Carry out a pressure check / visual inspection of both cylinders. It may be necessary to also observe the specific regulations applicable to the country of use.

### 12.5.3 Every 60 Months



Part or Assembly	Maintenance Task
JJ-CCR Rebreather	Return the equipment to the manufacturer or an approved service centre for a general service.

ALWAYS KNOW YOUR PO2

THIS MANUAL IS PRODUCED BY JJ-CCR ApS.

WE ARE PROUD OF BEEING THE REBREATHER  
MANUFACTURER OF YOUR CHOICE!

OUR TEAM INTEND TO SUPPORT YOU AS  
MUCH AS THEY CAN IN ORDER TO EXCEED  
YOUR EXPECTATIONS

